

Keysight E3631A Triple Output DC Power Supply

Notices

Copyright Notice

© Keysight Technologies 2002 - 2018
No part of this manual may be reproduced in any form or by any means (including electronic storage and retrieval or translation into a foreign language) without prior agreement and written consent from Keysight Technologies as governed by United States and international copyright laws.

Manual Part Number

E3631-90002

Edition

Edition 10, December 31, 2018

Printed in:

Printed in Malaysia

Published by:

Keysight Technologies
Bayan Lepas Free Industrial Zone,
11900 Penang, Malaysia

Technology Licenses

The hardware and/or software described in this document are furnished under a license and may be used or copied only in accordance with the terms of such license.

Declaration of Conformity

Declarations of Conformity for this product and for other Keysight products may be downloaded from the Web. Go to <http://www.keysight.com/go/conformity>. You can then search by product number to find the latest Declaration of Conformity.

U.S. Government Rights

The Software is “commercial computer software,” as defined by Federal Acquisition Regulation (“FAR”) 2.101. Pursuant to FAR 12.212 and 27.405-3 and Department of Defense FAR Supplement (“DFARS”) 227.7202, the U.S. government acquires commercial computer software under the same terms by which the software is customarily provided to the public. Accordingly, Keysight provides the Software to U.S. government customers under its standard commercial license, which is embodied in its End User License Agreement (EULA), a copy of which can be found at <http://www.keysight.com/find/sweula>. The license set forth in the EULA represents the exclusive authority by which the U.S. government may use, modify, distribute, or disclose the Software. The EULA and the license set forth therein, does not require or permit, among other things, that Keysight: (1) Furnish technical information related to commercial computer software or commercial computer software documentation that is not customarily provided to the public; or (2) Relinquish to, or otherwise provide, the government rights in excess of these rights customarily provided to the public to use, modify, reproduce, release, perform, display, or disclose commercial computer software or commercial computer software documentation. No additional government requirements beyond those set forth in the EULA shall apply, except to the extent that those terms, rights, or licenses are explicitly required from all providers of commercial computer software pursuant to the FAR and the DFARS and are set forth specifically in writing elsewhere in the EULA. Keysight shall be under no obligation to update, revise or otherwise modify the Software. With respect to any technical data as defined by FAR 2.101, pursuant to FAR 12.211 and 27.404.2 and DFARS 227.7102, the U.S. government acquires no greater than Limited Rights as defined in FAR 27.401 or DFAR 227.7103-5 (c), as applicable in any technical data.

Warranty

THE MATERIAL CONTAINED IN THIS DOCUMENT IS PROVIDED “AS IS,” AND IS SUBJECT TO BEING CHANGED, WITHOUT NOTICE, IN FUTURE EDITIONS. FURTHER, TO THE MAXIMUM EXTENT PERMITTED BY APPLICABLE LAW, KEYSIGHT DISCLAIMS ALL WARRANTIES, EITHER EXPRESS OR IMPLIED, WITH REGARD TO THIS MANUAL AND ANY INFORMATION CONTAINED HEREIN, INCLUDING BUT NOT LIMITED TO THE IMPLIED WARRANTIES OF MERCHANTABILITY AND FITNESS FOR A PARTICULAR PURPOSE. KEYSIGHT SHALL NOT BE LIABLE FOR ERRORS OR FOR INCIDENTAL OR CONSEQUENTIAL DAMAGES IN CONNECTION WITH THE FURNISHING, USE, OR PERFORMANCE OF THIS DOCUMENT OR OF ANY INFORMATION CONTAINED HEREIN. SHOULD KEYSIGHT AND THE USER HAVE A SEPARATE WRITTEN AGREEMENT WITH WARRANTY TERMS COVERING THE MATERIAL IN THIS DOCUMENT THAT CONFLICT WITH THESE TERMS, THE WARRANTY TERMS IN THE SEPARATE AGREEMENT SHALL CONTROL.

Safety Information

CAUTION

A CAUTION notice denotes a hazard. It calls attention to an operating procedure, practice, or the like that, if not correctly performed or adhered to, could result in damage to the product or loss of important data. Do not proceed beyond a CAUTION notice until the indicated conditions are fully understood and met.

WARNING

A WARNING notice denotes a hazard. It calls attention to an operating procedure, practice, or the like that, if not correctly performed or adhered to, could result in personal injury or death. Do not proceed beyond a WARNING notice until the indicated conditions are fully understood and met.

Certification

Keysight Technologies certifies that this product met its published specifications at the time of shipment. Keysight further certifies that its calibration measurements are traceable to the United States National Institute of Standard and Technology (formerly National Bureau of Standards), to the extent allowed by that organization's calibration facility, and to the calibration facilities of other International Standards Organization members.

Warranty

This Keysight product is warranted against defects in materials and workmanship for a period of one year from date of shipment. Duration and conditions of warranty for this product may be superseded when the product is integrated into (becomes a part of) other Keysight products. During the warranty period, Keysight will, at its option, either repair or replace products which prove to be defective. The warranty period begins on the date of delivery or on the date of installation if installed by Keysight.

For warranty service or repair, this product must be returned to a service facility designated by Keysight. For products returned to Keysight for warranty service, the Buyer shall prepay shipping charges to Keysight and Keysight shall pay shipping charges to return the product to the Buyer. However, the Buyer shall pay all shipping charges, duties, and taxes for products returned to Keysight from another country.

If Keysight is unable, within a reasonable time, to repair or replace any product to condition as warranted, the Customer shall be entitled to a refund of the purchase price upon return of the product to Keysight.

The warranty period begins on the date of delivery or on the date of installation if installed by Keysight.

Limitation of Warranty

The foregoing warranty shall not apply to defects resulting from improper or inadequate maintenance by the Buyer, Buyer-supplied products or interfacing, unauthorized modification or misuse, operation outside of the environmental specifications for the product, or improper site preparation or maintenance.

The design and implementation of any circuit on this product is the sole responsibility of the Buyer. Keysight does not warrant the Buyer's circuitry or malfunctions of Keysight products that result from the Buyer's circuitry. In addition, Keysight does not warrant any damage that occurs as a result of the Buyer's circuit or any defects that result from Buyer supplied products.

To the extent allowed by local law, Keysight makes no other warranty, expressed or implied, whether written or oral with respect to this product and specifically disclaims any implied warranty or condition of merchantability, fitness for a particular purpose or satisfactory quality.

For transactions in Australia and New Zealand: The warranty terms contained in this statement, except to the extent lawfully permitted, do not exclude, restrict, or modify and are in addition to the mandatory statutory rights applicable to the sale of this product.

Exclusive Remedies

To the extent allowed by local law, the remedies provided herein are the Buyer's sole and exclusive remedies. Keysight shall not be liable for any direct, indirect, special, incidental, or consequential damages (including lost profit or data), whether based on warranty, contract, tort, or any other legal theory.

Notice

The information contained in this document is subject to change without notice. To the extent allowed by local law, Keysight makes no warranty of any kind with regard to this material, including, but not limited to, the implied warranties of merchantability and fitness for a particular purpose.











To the extent allowed by local law, Keysight shall not be liable for errors contained herein or for incidental or consequential damages in connection with the furnishing, performance, or use of this material. No part of this document may be photocopied, reproduced, or translated to another language without the prior written consent of Keysight.

Restricted Rights

The Software and Documentation have been developed entirely at private expense. They are delivered and licensed as “commercial computer software” as defined in DFARS 252.227-7013 (Oct 1988), DFARS 252.211-7015 (May 1991), or DFARS 252.227-7014 (Jun 1995), as a “commercial item” as defined in FAR 2.101(a), or as “restricted computer software” as defined in FAR 52.227-19 (Jun 1987) (or any equivalent agency regulation or contract clause), whichever is applicable. You have only those rights provided for such Software and Documentation by the applicable FAR or DFARS clause or the Keysight standard software agreement for the product involved.

Safety Symbols

The following symbols on the instrument and in the documentation indicate precautions which must be taken to maintain safe operation of the instrument.

	Caution, risk of danger (refer to this manual for specific Warning or Caution information)		Direct current (DC)
	Protective conductor terminal		Alternating current (AC)
	Earth (ground) terminal		Out position of a bi-stable push control
	Frame or chassis terminal		In position of a bi-stable push control
	Positive binding post		Negative binding post

Safety Considerations

Read the information below before using this instrument.







The following general safety precautions must be observed during all phases of operation, service, and repair of this instrument. Failure to comply with these precautions or with specific warnings elsewhere in this manual violates safety standards for design, manufacture, and intended use of the instrument. Keysight Technologies assumes no liability for the customer's failure to comply with these requirements.

WARNING

DO NOT SUBSTITUTE PARTS OR MODIFY INSTRUMENT.

Because of the danger of introducing additional hazards, do not install substitute parts or perform any unauthorized modification to the instrument. Return the instrument to a Keysight Technologies Sales and Service Office for service and repair to ensure that safety features are maintained.

Regulatory Markings

	<p>The CE marking is a legal compliance marking of the European Community. This CE marking shows that the product complies with all the relevant European Legal Directives.</p>		<p>The CSA mark is a registered trademark of the Canadian Standards Association.</p>
	<p>The RCM mark is a registered trademark of the Australian Communications and Media Authority.</p>		<p>This symbol indicates the time period during which no hazardous or toxic substance elements are expected to leak or deteriorate during normal use. Forty years is the expected useful life of the product.</p>
<p>ICES/NMB-001</p>	<p>ICES/NMB-001 indicates that this ISM device complies with the Canadian ICES-001. Cet appareil ISM est conforme a la norme NMB-001 du Canada.</p>		<p>This symbol is a South Korean Class A EMC Declaration. This is a Class A instrument suitable for professional use and in electromagnetic environment outside of the home.</p>
	<p>This instrument complies with the WEEE Directive (2002/96/EC) marking requirement. This affixed product label indicates that you must not discard this electrical or electronic product in domestic household waste.</p>		

Environmental conditions

This instrument is designed for indoor use and in an area with low condensation. The table below shows the general environmental requirements for this instrument.

Environmental condition	Requirements
Temperature	Operating condition – 0 °C to 40 °C Storage condition – 20 °C to 70 °C
Humidity	Up to 80% RH
Altitude	Up to 2000 m
Installation category	II
Pollution degree	2

Waste Electrical and Electronic Equipment (WEEE) Directive

This instrument complies with the WEEE Directive marking requirement. This affixed product label indicates that you must not discard this electrical or electronic product in domestic household waste.

Product category:

With reference to the equipment types in the WEEE directive Annex 1, this instrument is classified as a “Monitoring and Control Instrument” product.

The affixed product label is as shown below.



Do not dispose in domestic household waste.

To return this unwanted instrument, contact your nearest Keysight Service Center, or visit <http://about.keysight.com/en/companyinfo/environment/takeback.shtml> for more information.

Sales and Technical Support

To contact Keysight for sales and technical support, refer to the support links on the following Keysight websites:

- www.keysight.com/find/powersupply
(product-specific information and support, software and documentation updates)
- www.keysight.com/find/assist
(worldwide contact information for repair and service)

Keysight E3631A Triple Output DC Power Supply

The Keysight E3631A is a high performance 80 watt-triple output DC power supply with GPIB and RS-232 interfaces. The combination of bench-top and system features in this power supply provides versatile solutions for your design and test requirements.

Convenient bench-top features

- Triple output
- Easy-to-use knob control for voltage and current settings
- Highly visible vacuum-fluorescent display for voltage and current meters
- Tracking operation for ± 25 V outputs
- Excellent load and line regulation and low ripple and noise
- Operating states storage
- Portable, ruggedized case with non-skid feet

Flexible system features

- GPIB (IEEE-488) and RS-232 interfaces are standard
- SCPI (Standard Commands for Programmable Instruments) compatibility
- I/O setup easily done from front-panel

The Front Panel at a Glance

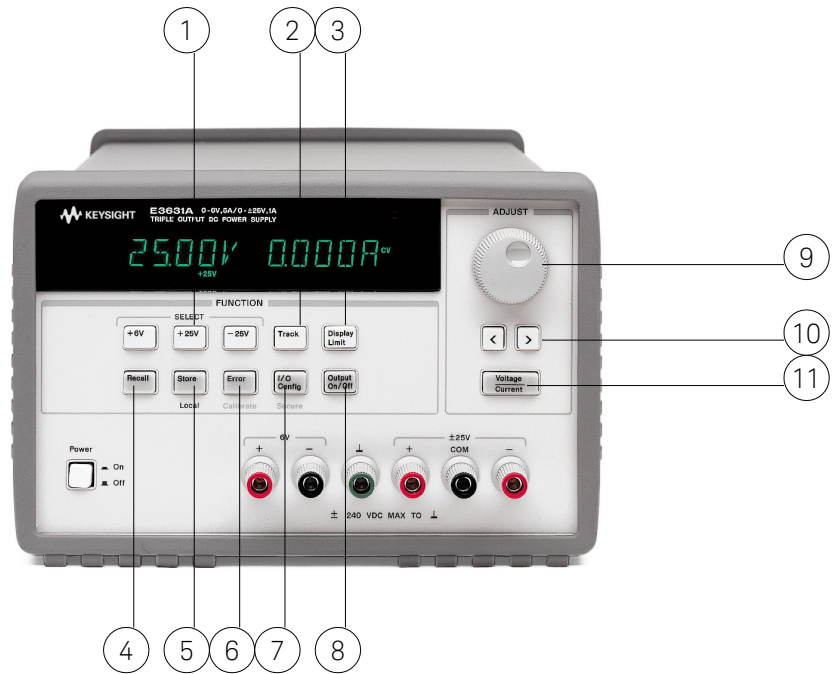

1	Meter and adjust selection keys	7	I/O Configuration / Secure key
2	Tracking enable/disable key	8	Output On/Off key
3	Display limit key	9	Control knob
4	Recall operating state key	10	Resolution selection keys
5	Store operating state/Local key	11	Voltage/current adjust selection key
6	Error/Calibrate key		

- 1 Meter and adjust selection keys** Select the output voltage and current of any one supply (+6 V, +25 V, or –25 V output) to be monitored on the display and allow knob adjustment of that supply.
- 2 Tracking enable / disable key** Enables / disables the track mode of ± 25 V supplies.
- 3 Display limit key** Shows the voltage and current limit values on the display and allows knob adjustment for setting limit values.
- 4 Recall operating state key** Recalls a previously stored operating state from location “1”, “2”, or “3”.
- 5 Store operating state / Local key¹** Stores an operating state in location “1”, “2”, or “3” / or returns the power supply to local mode from remote interface mode.
- 6 Error / Calibrate key²** Displays error codes generated during operations, self-test and calibration / or enables calibration mode (the power supply must be unsecured before performing calibration).
- 7 I/O Configuration / Secure key³** Configures the power supply for remote interfaces / or secure and unsecure the power supply for calibration.
- 8 Output On/Off key** Enables or disables all three power supply outputs. This key toggles between two states.
- 9 Control knob** Increases or decreases the value of the blinking digit by turning clockwise or counter clockwise.
- 10 Resolution selection keys** Move the flashing digit to the right or left.
- 11 Voltage/current adjust selection key** Selects the knob function to voltage control or current control.

¹The key can be used as the “Local” key when the power supply is in the remote interface mode.

²You can enable the “calibration mode” by holding down this key when you turn on the power supply.

³You can use it as the “Secure” or “Unsecure” key when the power supply is in the calibration mode.

Front-panel Voltage and Current Limit Settings

You can set the voltage and current limit values from the front panel using the following method.

Use the voltage/current adjust selection key, the resolution selection keys, and the control knob to change the monitoring or limiting value of voltage or current.

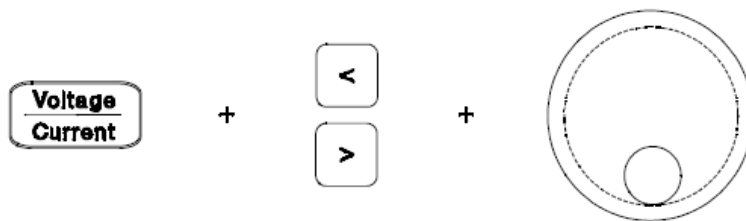

- 1 Press the “Display Limit” key after turning on the power supply.
- 2 Set the knob to the voltage control mode or current control mode using the voltage/current adjust selection key.
- 3 Move the blinking digit to the appropriate position using the resolution selection keys.
- 4 Change the blinking digit to the desired value using the control knob.
- 5 Press the “Output On/Off” key to enable the output. After about 5 seconds, the display will go to the output monitor mode automatically to display the voltage and current at the output.

NOTE

All front panel keys and controls can be disabled with remote interface commands. The Keysight E3631A must be in “Local” mode for the front panel keys and controls to function.

Display Annunciators

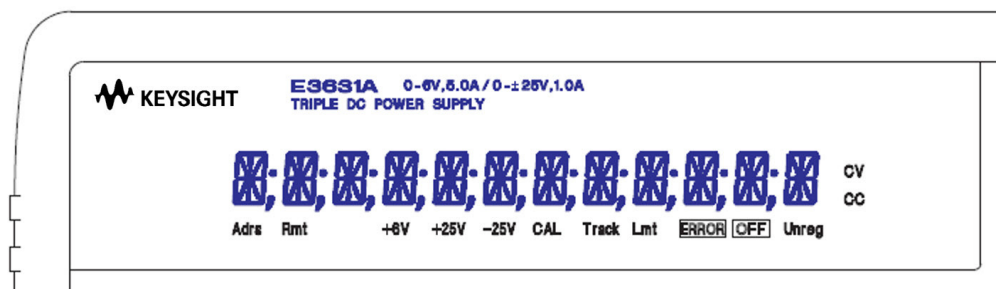

Adrs	Power supply is addressed to listen or talk over a remote interface.
Rmt	Power supply is in remote interface mode.
+6V	Displays the output voltage and current for +6 V supply. Knob is active for +6 V supply.
+25V	Displays the output voltage and current for +25 V supply. Knob is active for +25 V supply.
-25V	Displays the output voltage and current for -25 V supply. Knob is active for -25 V supply.
CAL	Power supply is in calibration mode.
Track	The outputs of +25V and -25 V supplies are in track mode.
Limit	The display shows the voltage and current limit value of a selected supply.
ERROR	Hardware or remote interface command errors are detected and also the error bit has not been cleared.
OFF	The three outputs of the power supply are disabled.
Unreg	The displayed output is unregulated (output is neither CV nor CC).
CV	The displayed output is in constant-voltage mode.
CC	The displayed output is in constant-current mode.

To review the display annunciators, hold down “Display Limit” key as you turn on the power supply.

The Rear Panel at a Glance

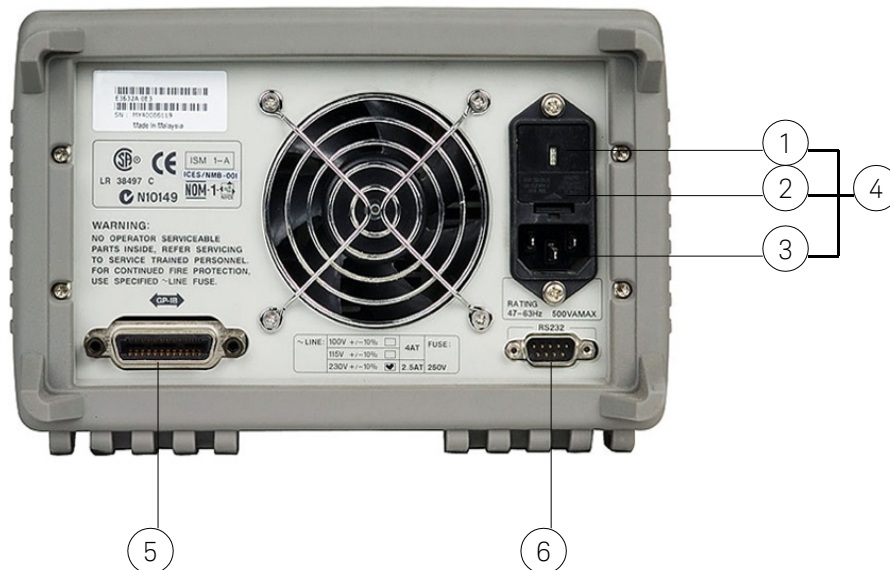

1	Power-line voltage setting	4	Power-line module
2	Power-line fuse-holder assembly	5	GPIB (IEEE-488) interface connector
3	AC inlet	6	RS-232 interface connector

Use the front-panel “I/O Config” key to:

- Select the GPIB or RS-232 interface (see [Chapter 3](#)).
- Set the GPIB bus address (see [Chapter 3](#)).
- Set the RS-232 baud rate and parity (see [Chapter 3](#)).

In This Book

Chapter 1, "General Information" contains a general description of your power supply. This chapter also provides instructions for checking your power supply, connecting to ac power, and selecting power-line voltage.

Chapter 2, "Initial Operation" ensures that the power supply develops its rated outputs and properly responds to operation from the front panel.

Chapter 3, "Front-Panel Operation" describes in detail the use of front-panel keys and how they are used to operate the power supply from the front panel. This chapter also shows how to configure the power supply for the remote interface and gives a brief introduction to the calibration features.

Chapter 4, "Remote Interface Reference" contains reference information to help you program the power supply over the remote interface. This chapter also explains how to program for status reporting.

Chapter 5, "Error Messages" lists the error messages that may appear as you are working with the power supply. Each listing contains information to help you diagnose and solve the problem.

Chapter 6, "Application Programs" contains some remote interface applications to help you develop programs for your application.

Chapter 7, "Tutorial" describes basic operation of linear power supplies and gives specific details on the operation and use of the Keysight E3631A power supplies.

Chapter 8, "Specifications" lists the power supply's specifications.

NOTE

If you have questions relating to the operation of the power supply, call 1-800-829-4444 in the United States, or contact your nearest Keysight Technologies Sales Office.

THIS PAGE HAS BEEN INTENTIONALLY LEFT BLANK.

Table of Contents

Certification	3
Warranty	3
Limitation of Warranty	4
Exclusive Remedies	4
Notice	5
Restricted Rights	5
Safety Symbols	6
Safety Considerations	7
Regulatory Markings	8
Environmental conditions	9
Waste Electrical and Electronic Equipment (WEEE) Directive	10
Product category:	10
Sales and Technical Support	10
Keysight E3631A Triple Output DC Power Supply	11
The Front Panel at a Glance	12
Front-panel Voltage and Current Limit Settings	14
Display Annunciators	15
The Rear Panel at a Glance	16
In This Book	17
List of Figures	23
List of Tables	25
1 General Information	
Safety Considerations	28
Safety and EMC requirements	28
Options and accessories	29
Description	30
Installation	32

Initial inspection	32
Cooling and location	32
Input power requirement	36
Power-line cord	36
Power-line voltage selection	37
2 Initial Operation	
Preliminary checkout	42
Power-on checkout	43
Output checkout	44
Voltage output checkout	44
Current output checkout	46
3 Front-Panel Operation	
Front-panel operation overview	50
Constant voltage operation	51
Constant current operation	54
Tracking operation	57
Storing and recalling operating states	58
Disabling the outputs	60
Knob locking	61
System-related operations	62
Remote interface configuration	66
GPIB interface configuration	71
RS-232 interface configuration	72
Calibration overview	76
4 Remote Interface Reference	
SCPI command summary	83
Simplified Programming Overview	89
Using the APPLY command	92
Output setting and operation commands	93

Output on/off and tracking operation commands	96
Output setting commands	96
Triggering commands	99
System-Related Commands	103
Calibration commands	106
RS-232 Interface Commands	108
The SCPI status registers	109
The questionable status register	113
The standard event register	115
Status reporting commands	120
An introduction to the SCPI language	125
SCPI Conformance Information	131
IEEE-488 Conformance information	136
5 Error Messages	
Error Messages	138
Execution Errors	139
Self-Test Errors	144
Calibration Errors	145
6 Application Programs	
Keysight BASIC Programs	148
C and QuickBASIC language programs	148
Using the APPLY command	149
C / GPIB (Program 1)	150
C / GPIB (Program 1)	154
Using the Low-Level Commands	158
Keysight BASIC / GPIB (Program 2)	158
QuickBASIC / GPIB (Program 2)	159
Using the Status Registers	163
Keysight BASIC / GPIB (Program 3)	163
RS-232 Operation Using QuickBASIC	166

	RS-232 Operation Using QuickBASIC (Program 4)	166
7	Tutorial	
	Overview of Keysight E3631A Operation	170
	Output Characteristics	172
	Connecting the Load	177
	Connecting the load	177
	Multiple loads	177
	Load Consideration	178
	Extending the Voltage	180
	Series Connections	180
	Remote Programming	181
	Reliability	183
8	Specifications	
	Performance Specifications	186
	Supplemental Characteristics	188

List of Figures

Figure 7-1	Diagram of simple series power supply with tap selection	170
Figure 7-2	Block diagram of the three supplies showing the isolation	171
Figure 7-3	Ideal constant voltage power supply	172
Figure 7-4	Ideal constant current power supply	173
Figure 7-5	Output characteristics	174
Figure 7-6	Simplified diagram of common mode and normal mode sources of noise	176
Figure 7-7	Speed of response - programming up (full load)	181
Figure 7-8	Speed of response -programming down	182
Figure 8-1	Dimensions of keysight E3631A power supply	190

THIS PAGE HAS BEEN INTENTIONALLY LEFT BLANK.

List of Tables

Table 4-1	Keysight E3631A Programming Ranges and Output Identifiers	91
Table 4-2	Bit definitions - questionable status register	113
Table 4-3	Bit definitions - standard event register	115
Table 4-4	Bit definitions - status byte summary register	116
Table 7-1	Wire Rating	177
Table 7-2	Slew Rate	178

THIS PAGE HAS BEEN INTENTIONALLY LEFT BLANK.

1 General Information

This chapter provides a general description of your power supply. This chapter also contains instructions for initial inspection, location and cooling for bench and rack operation, selecting the power-line voltage, and connecting your power supply to ac power.

- Safety Considerations 28
- Options and accessories 29
- Description 30
- Installation 32
- Input power requirement 36

Safety Considerations

This power supply is a Safety Class I instrument, which means that it has a protective earth terminal. That terminal must be connected to earth ground through a power source with a 3-wire ground receptacle.

Before installation or operation, check the power supply and review this manual for safety markings and instructions. Safety information for specific procedures is located at the appropriate places in this manual. See also “Safety” at the beginning of this manual for general safety information.

Safety and EMC requirements

This power supply is designed to comply with the following safety and EMC (Electromagnetic Compatibility) requirements:

Safety

- IEC 61010-1:2001 / EN 61010-1:2001
- CAN/CSA-C22.2 No. 61010.1-04
- ANSI/UL61010-1:2004

EMC

- IEC 61326-1:2005/EN61326-1:2006
- CISPR11:2003/EN55011:2007
- Canada: ICES/NMB-001:Issue 4, June 2006
- Australia/New Zealand: AS/NZS CISPR 11:2004

Options and accessories

Options

Options 0EM, 0E3, and 0E9 determine which power-line voltage is selected at the factory. The standard unit is configured for 115 VAC \pm 10%, 47-63 Hz input voltage. For more information about changing the power-line voltage setting, see **Power-line voltage selection** in this chapter.

Option	Description
0EM	115 VAC \pm 10%, 47-63 Hz input voltage
0E3	230 VAC \pm 10%, 47-63 Hz input voltage
0E9	100 VAC \pm 10%, 47-63 Hz input voltage
1CM	Rack mount kit (Keysight part number 5062-3957)
0L2	Extra English manual set (local language manual files are included on the CD-ROM, Keysight part number 5964-8251)

Accessories

The accessories listed below may be ordered from your local Keysight Technologies Sales Office either with the power supply or separately.

Keysight no.	Description
10833A	GPIB cable, 1 m (3.3 ft.)
10833B	GPIB cable, 2 m (6.6 ft.)
34398A	RS-232, 9 pin (f) to 9 pin (f), 2.5 m (8.2 ft.) cable; plus 9 pin (m) to 25 pin (f) adapter
34399A	RS-232 adapter kit (contains 4 adapters):
	9 pin (m) to 25 pin (m) for use with PC or printer
	9 pin (m) to 25 pin (f) for use with PC or printer
	9 pin (m) to 25 pin (m) for use with modem
	9 pin (m) to 9 pin (m) for use with modem

Description

The Keysight E3631A power supply features a combination of programming capabilities and linear power supply performance that makes it ideal for power systems applications. The triple power supply delivers 0 to ± 25 V outputs rated at 0 to 1 A and 0 to +6 V output rated at 0 to 5 A. The ± 25 V supplies also provide 0 to ± 25 V tracking output to power operational amplifiers and circuits requiring symmetrically balanced voltages. The 0 to ± 25 V outputs track each other within $\pm(0.2\% \text{ output} + 20 \text{ mV})$ in the track mode. The ± 25 V outputs can also be used in series as a single 0 to 50 V/1 A supply.

The voltage and current of each supply can be adjusted independently from the front panel or programmed over the GPIB or RS-232 interface. Using the front panel keys and the control knob, you can adjust the voltage and current of a selected output; enable or disable track mode; store and recall operating states; enable or disable three outputs; calibrate the power supply including changing the calibration security; return the power supply to local operating mode; and configure the power supply for remote interface operation.

From the front-panel VFD (vacuum-fluorescent display), you can monitor actual values of output voltage and current (meter mode) or voltage and current limit values (limit mode), check the operating status of the power supply from the annunciators, and check the type of error from the displayed error codes (messages).

When operated over the remote interface, the power supply can be both a listener and a talker. Using an external controller, you can instruct the power supply to set outputs and to send the status data back over the GPIB or RS-232. Readback capabilities include reading back output voltage and current; present and stored status; and error messages. The following functions are implemented over the GPIB or RS-232:

- Voltage and current programming
- Voltage and current readback
- Enable or disable track mode
- Present and stored status readback
- Programming syntax error detection

- Voltage and current calibration
- Output on or off
- Self-test

The front panel includes a VFD for displaying the output voltage and current. Two 4-digit voltage and current meters accurately show the actual or limit values of a selected supply simultaneously. Three meter selection keys choose the voltage and current of any one output to be monitored on the display.

Connections to the power supply's output and to chassis ground are made to binding posts on the front panel. The +25V and –25V supply's outputs share a common output terminal which is isolated from chassis ground. The positive and negative terminals of each output can be grounded, or each output can be kept within ± 240 VDC from the chassis ground. The power supply is shipped with a detachable, 3-wire grounding type power cord. The ac line fuse is an extractor type on the rear panel.

The power supply can be calibrated from the front panel directly or with a controller over the GPIB or RS-232 interface using calibration commands. Correction factors are stored in non-volatile memory and are used during output programming. Calibration from the front panel or a controller eliminates the need to remove the top cover or even the need to remove the power supply from your system cabinet. You can guard against unauthorized calibration by using the "Secured" calibration protection function.

Installation

Initial inspection

When you receive your power supply, inspect it for any obvious damage that may have occurred during shipment. If any damage is found, notify the carrier and the nearest Keysight Sales Office immediately. Warranty information is shown in the front of this manual.

Keep the original packing materials in case the power supply has to be returned to Keysight Technologies in the future. If you return the power supply for service, attach a tag identifying the owner and model number. Also include a brief description of the problem.

Mechanical check

This check confirms that there are no broken keys or knob, that the cabinet and panel surfaces are free of dents and scratches, and that the display is not scratched or cracked.

Electrical check

Chapter 2 describes an initial operation procedure which, when successfully completed, verifies to a high level of confidence that the power supply is operating in accordance with its specifications. Detailed electrical verification procedures are included in the *Service Guide*.

Cooling and location

Cooling

The power supply can operate without loss of performance within the temperature range of 0°C to 40°C, and with derated output current from 40°C to 55°C. A fan cools the power supply by drawing air through the rear panel and exhausting it out the sides. Using a Keysight rack mount will not impede the flow of air.

Bench Operation

Your power supply must be installed in a location that allows sufficient space at the sides and rear of the power supply for adequate air circulation. The rubber bumpers must be removed for rack mounting.

Rack mounting

The power supply can be mounted in a standard 19-inch rack cabinet using one of the three optional kits available. A rack-mounting kit for a single instrument is available as Option 1CM (P/N 5063-9243). Installation instructions and hardware are included with each rack-mounting kit. Any Keysight System 2 instrument of the same size can be rack-mounted beside the Keysight E3631A power supply.

Remove the front and rear bumpers before rack-mounting the power supply.

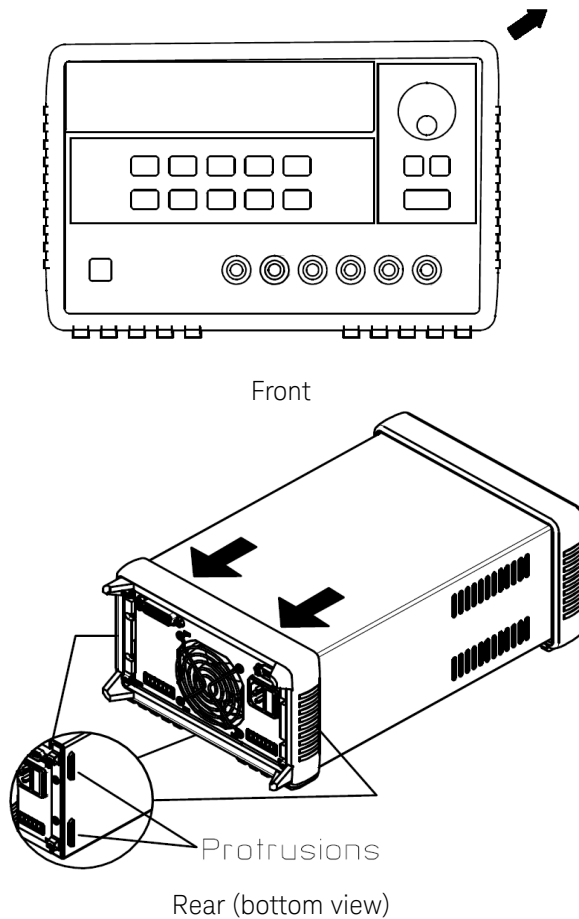

General Information

To remove the rear bumper, pull the bumper off from the tops as there are protrusions on the sides and bottom of the cover.

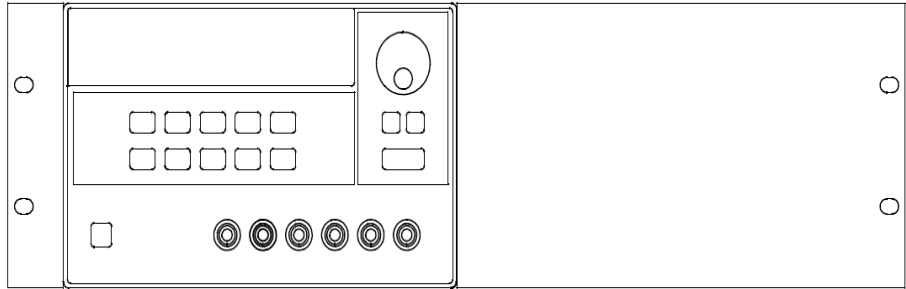

To rack mount a single instrument, order adapter kit 5063-9243.

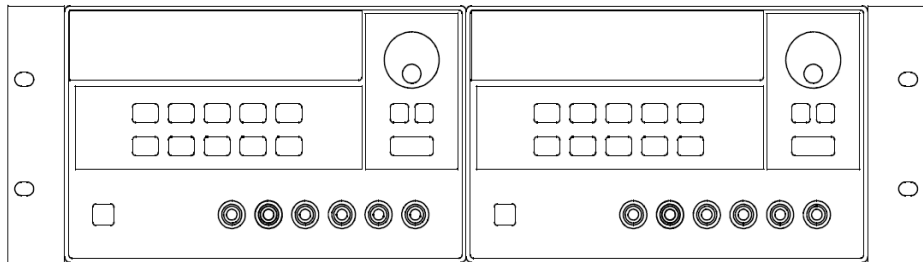

To rack mount two instrument of the same depth side-by-side, order lock-link lit 5061-9694 and flange kit 5063-9214.

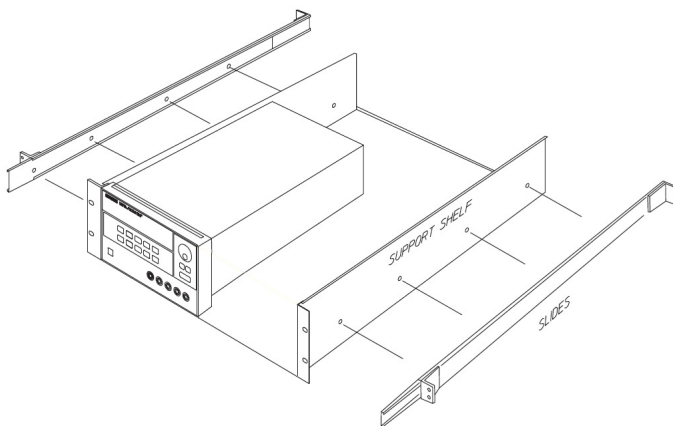

To install two instrument in a sliding support shelf, order support shelf 5063-9256, and slide kit 1494-0015.

Input power requirement

You can operate your power supply from a nominal 100 V, 115 V, or 230 V single phase ac power source at 47 to 63 Hz. An indication on the rear panel shows the nominal input voltage set for the power supply at the factory. If necessary, you can change the power-line voltage setting according to the instructions on the next page.

Power-line cord

The power supply is shipped from the factory with a power-line cord that has a plug appropriate for your location. Contact the nearest Keysight Sales and Service Office if the wrong power-line cord is included with your power supply. Your power supply is equipped with a 3-wire grounding type power cord; the third conductor being the ground. The power supply is grounded only when the power-line cord is plugged into an appropriate receptacle. Do not operate your power supply without adequate cabinet ground connection.

Power-line voltage selection

Power-line voltage selection is accomplished by adjusting two components: power-line voltage selector and power-line fuse on the power-line module of the rear panel. To change the power-line voltage, proceed as follows:

- 1 Remove the power cord. Remove the fuse-holder assembly with a flat-blade screwdriver from the rear panel.

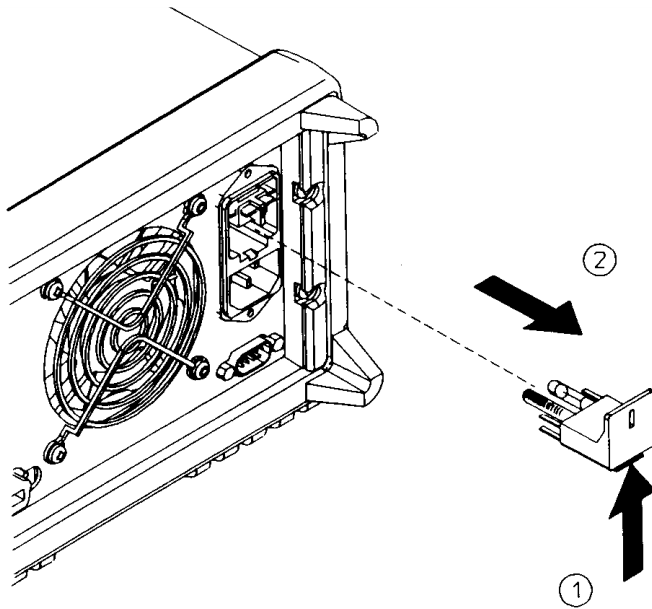

General Information

- 2 Install the correct line fuse. Remove the power-line voltage selector from the power-line module.

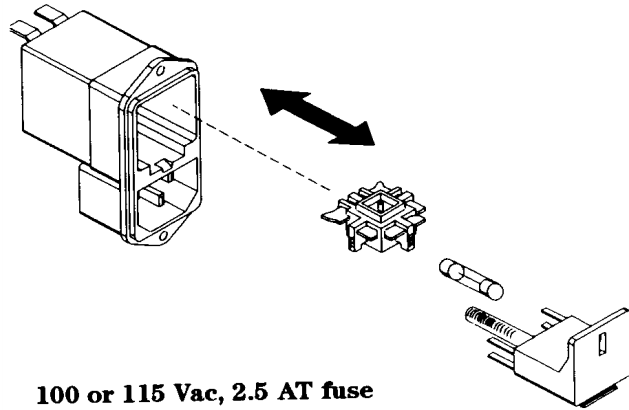

100 or 115 Vac, 2.5 AT fuse
230 Vac, 2 AT fuse

- 3 Rotate the power-line voltage selector until the correct voltage appears.

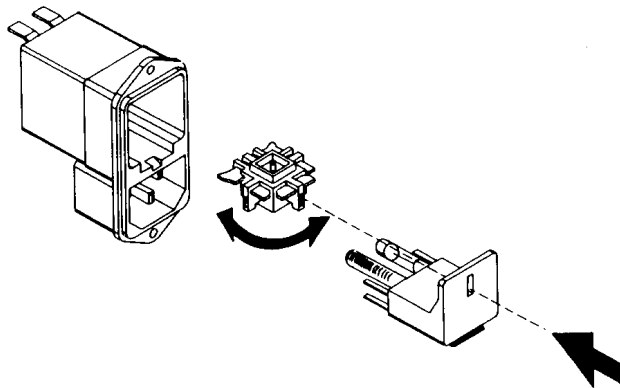

100, 115, or 230 Vac

- 4 Replace the power-line voltage selector and the fuse-holder assembly in the rear panel.

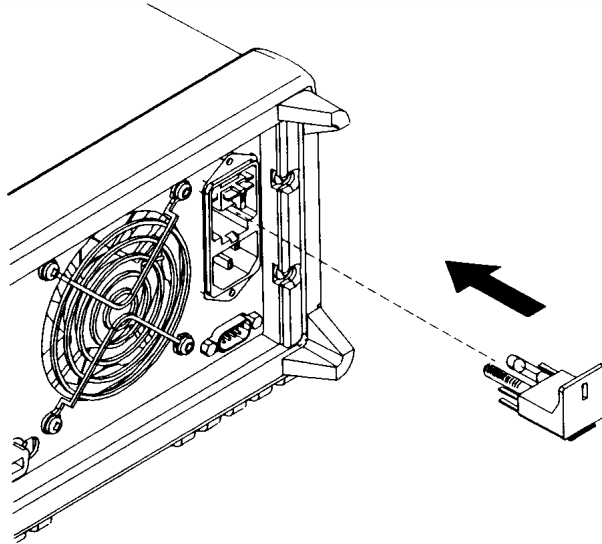

THIS PAGE HAS BEEN INTENTIONALLY LEFT BLANK.

2 Initial Operation

There are three basic tests in this chapter. The automatic power-on test includes a self-test that checks the internal microprocessors and allows the user visually to check the display. The output check ensures that the power supply develops its rated outputs and properly responds to operation from the front panel. For complete performance and/or verification tests, refer to the Service Guide.

This chapter is intended for both the experienced and the inexperienced user because it calls attention to certain checks that should be made prior to operation.

- Preliminary checkout 42
- Power-on checkout 43
- Output checkout 44

Preliminary checkout

The following steps help you verify that the power supply is ready for use.

- 1 Verify the power-line voltage setting on the rear panel.** The power-line voltage is set to the proper value for your country when the power supply is shipped from the factory. Change the voltage setting if it is not correct. The settings are: 100, 115, or 230 VAC.
- 2 Verify that the correct power-line fuse is installed.** The correct fuse is installed for your country when the power supply is shipped from the factory. For 100 or 115 VAC operation, you must use a 2.5 AT fuse. For 230 VAC operation, you must use a 2.0 AT fuse.
- 3 Connect the power-line cord and turn on your power supply.** The front-panel display will light up and a power-on self-test occurs automatically when you turn on the power supply.

See [Power-line voltage selection](#) if you need to change the power-line voltage or the power-line fuse.

NOTE

To replace the 2.5 AT fuse, order Keysight part number 2110-0913.
To replace the 2 AT fuse, order Keysight part number 2110-0982.

Power-on checkout

The power-on test includes an automatic self-test that checks the internal microprocessors and allows the user visually to check the display. You will observe the following sequence on the display after pressing the front panel power switch to on.

- 1 All segments of the display including all annunciators will turn on for about one second.** To review the annunciators, hold down the *Display Limit* key as you turn on the power supply.
- 2 The GPIB address or RS-232 message will then be displayed for about one second.** The GPIB address is set to “5” when the power supply is shipped from the factory for remote interface configuration. If this is not the first time the power supply is turned on, a different interface (RS-232) or a different GPIB address may appear. See “[Remote interface configuration](#)” on page 66 in [Chapter 3](#) if you need to change the remote interface configuration.

ADDR 5 (or RS-232)

- 3 The “OFF” and “+6V” annunciators are on. All others are off.** The power supply will go into the power-on / reset state; all outputs are disabled (the OFF annunciator turns on); the display is selected for the +6V supply (the +6V annunciator turns on); and the knob is selected for voltage control.
- 4 Enable the outputs.** Press the “Output On/Off” key to enable the outputs. The **OFF** annunciator turns off and the +6V and CV annunciators are lit. The blinking digit can be adjusted by turning the knob. Notice that the display is in the meter mode. “Meter mode” means that the display shows the actual output voltage and current.

Output On/Off

NOTE

If the power supply detects an error during power-on self-test, the ERROR annunciator will turn on. See [Error Messages](#), for more information in [Chapter 5](#).

Output checkout

The following procedures check to ensure that the power supply develops its rated outputs and properly responds to operation from the front panel. For complete performance and verification tests, refer to the Service Guide.

Voltage output checkout

The following steps verify basic voltage functions with no load.

- 1 Turn on the power supply.

Power

The power supply will go into the *power-on / reset state*; all outputs are disabled (the OFF annunciator turns on); the display is selected for the +6V supply (the +6V annunciator turns on); and the knob is selected for voltage control.

- 2 Enable the outputs.

Output On/Off

The OFF annunciator turns off and the +6V and CV annunciators are lit. The blinking digit can be adjusted by turning the knob. Notice that the display is in the meter mode. “Meter mode” means that the display shows the actual output voltage and current.

- 3 Check that the front-panel voltmeter properly responds to knob control for the +6V supply.



Turn the knob clockwise or counter clockwise to check that the voltmeter responds to knob control and the ammeter indicates nearly zero.

- 4 Ensure that the voltage can be adjusted from zero to the maximum rated value.¹

Adjust the knob until the voltmeter indicates 0 volts and then adjust the knob until the voltmeter indicates 6.0 volts.

NOTE

You can use the resolution selection keys to move the blinking digit to the right or left when setting the voltage.

- 5** Check the voltage function for the +25V supply.

+25V

Select the meter and adjust selection key for the +25V supply. The CV annunciator is still lit and the +25V annunciator will turn on. Repeat steps (3) and (4) to check the voltage function for the +25V supply.

- 6** Check the voltage function for the -25V supply.

-25V

Select the meter and adjust selection key for the -25V supply. The CV annunciator is still lit and the -25V annunciator will turn on. Repeat steps (3) and (4) to check the voltage function for the -25V supply.

Current output checkout

The following steps check basic current functions with a short across the appropriate supply's output.

- 1 Turn on the power supply.

Power

The power supply will go into the power-on / reset state; all outputs are disabled (the OFF annunciator turns on); the display is selected for the +6V supply (the +6V annunciator turns on); and the knob is selected for voltage control.

- 2 Connect a short across (+) and (–) output terminals of the +6V supply with an insulated test lead.

Output On/Off

- 3 Enable the outputs.

The OFF annunciator turns off and the +6V annunciator turns on. The CV or CC annunciator is lit depending on the resistance of the test lead. The blinking digit can be adjusted by turning the knob. Notice that the display is in the meter mode. "Meter mode" means that the display shows the actual output voltage and current.

- 4 Adjust the voltage limit value to 1.0 volt.

Display Limit

Set the display to the limit mode (the Lmt annunciator will be blinking). Adjust the voltage limit to 1.0 volt to assure CC operation. The CC annunciator will light.

- 5 Check that the front-panel ammeter properly responds to knob control for the +6V supply.

Vol/Cur

Set the knob to the current control, and turn the knob clockwise or counter clockwise when the display is in the meter mode (the Lmt annunciator is off). Check that the ammeter responds to knob control and the voltmeter

indicates nearly zero (actually, the voltmeter will show the voltage drop caused by the test lead).

- 6 Ensure that the current can be adjusted from zero to the maximum rated value.¹



Adjust the knob until the ammeter indicates 0 amps and then until the ammeter indicates 5.0 amps.

- 7 Check the current function for the +25V supply.

+25V

Disable the outputs by pressing the “Output On/Off” key and connect a short across (-) and (COM) output terminals of $\pm 25V$ supply with an insulated test lead. Repeat steps (3) through (6) after selecting the meter and adjust selection key for the $-25V$ supply.

- 8 Check the current function for the $-25V$ supply.

$-25V$

Disable the outputs by pressing the “Output On/Off” key and connect a short across (-) and (COM) output terminals of $\pm 25V$ supply with an insulated test lead. Repeat steps (3) through (6) after selecting the meter and adjust selection key for the $-25V$ supply.

NOTE

If an error has been detected during the output checkout procedures, the ERROR annunciator will turn on. See [Error Messages](#) for more information in [Chapter 5](#)

¹ You can use the resolution selection keys to move the blinking digit to the right or left when setting the current.

THIS PAGE HAS BEEN INTENTIONALLY LEFT BLANK.

3 Front-Panel Operation

So far you have learned how to install your power supply and perform initial operation. During the initial operation, you were briefly introduced to operating from the front panel as you learned how to check basic voltage and current functions. This chapter will describe in detail the use of these front-panel keys and show how they are used to accomplish power supply operation.

- Front-panel operation overview 50
- Constant voltage operation 51
- Constant current operation 54
- Tracking operation 57
- Storing and recalling operating states 58
- Disabling the outputs 60
- Knob locking 61
- System-related operations 62
- Remote interface configuration 66
- GPIB interface configuration 71
- RS-232 interface configuration 72
- Calibration overview 76

NOTE

See “Error Messages”, for more information starting in Chapter 5 if you encounter any errors during front-panel operation.

Front-panel operation overview

The following section describes an overview of the front-panel keys before operating your power supply.

- The power supply is shipped from the factory configured in the front-panel operation mode. At power-on, the power supply is automatically set to operate in the front-panel operation mode. When in this mode, the front-panel keys can be used. When the power supply is in remote operation mode, you can return to front-panel operation mode at any time by pressing the “Local” key if you did not previously send the front-panel lockout command. A change between front panel and remote operation modes will not result in a change in the output parameters.
- When you press the “Display Limit” key (the Lmt annunciator blinks), the display of the power supply goes to the limit mode and the present limit values of the selected supply will be displayed. In this mode, you can also observe the change of the limit values when adjusting the knob. If you press the “Display Limit” key again or let the display time-out after several seconds, the power supply will return the display to the meter mode (the Lmt annunciator turns off). In this mode, the actual output voltage and current will be displayed.
- All outputs of the power supply can be enabled or disabled from the front panel using the “Output On/Off” key. When the output of the power supply is off, the OFF annunciator turns on and the three outputs are disabled.
- The display provides the present operating status of the power supply with annunciators and also informs the user of error codes. For example, the +6V supply is operating in CV mode and controlled from the front panel, then the CV and +6V annunciators will turn on. If, however, the power supply is remotely controlled, the Rmt annunciator will also turn on, and when the power supply is being addressed over GPIB interface, the Adrs annunciator will turn on. See [“Display Annunciators”](#) on page 15 for more information.

Constant voltage operation

To set up the power supply for constant voltage (CV) operation, proceed as follows.

- 1 Connect a load to the desired output terminals.

With power-off, connect a load to the desired output terminals.

- 2 Turn on the power supply.

Power

The power supply will go into the power-on / reset state; all outputs are disabled (the OFF annunciator turns on); the display is selected for the +6V supply (the +6V annunciator turns on); and the knob is selected for voltage control.

- 3 Enable the outputs.

Output On/Off

The OFF annunciator turns off and the +6V and CV annunciators are lit. The blinking digit can be adjusted by turning the knob. Notice that the display is in the meter mode. “Meter mode” means that the display shows the actual output voltage and current.

To set up the power supply for +25V supply or –25V supply operation, you should press the “+25V” or “–25V” key to select the display and adjust for +25V supply or –25V supply before proceeding to the next step.

- 4 Set the display for the limit mode.

Display Limit

Notice that the Lmt annunciator blinks, indicating that the display is in the limit mode. When the display is in the limit mode, you can see the voltage and current limit values of the selected supply.

NOTE

In constant voltage mode, the voltage values between the meter mode and limit mode are the same, but the current values are not. Further if the display is in the meter mode, you cannot see the change of current limit value when adjusting the knob. We recommend that you should set the display to “limit” mode to see the change of current limit value in the constant voltage mode whenever adjusting the knob.

- 5** Adjust the knob for the desired current limit.

Vol/Cur

Check that the Lmt annunciator still blinks. Set the knob for current control. The second digit of ammeter will be blinking. Adjust the knob to the desired current limit.

- 6** Adjust the knob for the desired output voltage.

Vol/Cur

Set the knob for voltage control. The second digit of the voltmeter will be blinking. Adjust the knob to the desired output voltage.

- 7** Return to the meter mode.

Display Limit

Press the “Display Limit” key or let the display time-out after several seconds to return to the meter mode. Notice that the Lmt annunciator turns off and the display returns to the meter mode. In the meter mode, the display shows the actual output voltage and current of the selected supply.

- 8** Verify that the power supply is in the constant voltage mode.

If you operate the +6V supply in the constant voltage (CV) mode, verify that CV and +6V annunciators are lit. If you operate the power supply for the +25V supply or the -25V supply, the +25V or -25V annunciator will turn on. If the CC annunciator is lit, choose a higher current limit.

NOTE

During actual CV operation, if a load change causes the current limit to be exceeded, the power supply will automatically crossover to the constant current mode at the preset current limit and the output voltage will drop proportionately.

¹ You can use the resolution selection keys to move the blinking digit to the right or left when setting the voltage and current.

Constant current operation

To set up the power supply for constant current (CC) operation, proceed as follows.

- 1 Connect a load to the output terminals of the desired supply.
With power-off, connect a load to the desired output terminals.
- 2 Turn on the power supply.

Power

The power supply will go into the power-on / reset state; all outputs are disabled (the OFF annunciator turns on); the display is selected for the +6V supply (the +6V annunciator turns on); and the knob is selected for voltage control.

- 3 Enable the outputs.

Output On/Off

The OFF annunciator turns off and the +6V and CV annunciators are lit. The blinking digit can be adjusted by turning the knob. Notice that the display is in the meter mode. “Meter mode” means that the display shows the actual output voltage and current.

To set up the power supply for +25V supply or –25V supply operation, you should press the “+25V” or “–25V” key to select the display and adjust for +25V supply or –25V supply before proceeding to the next step.

- 4 Set the display for the limit mode.

Display Limit

Notice that the Lmt annunciator blinks, indicating that the display is in the limit mode. When the display is in the limit mode, you can see the voltage and current limit values of the selected supply.

NOTE

In constant current mode, the current values between the meter mode and limit mode are the same, but the voltage values are not. Further if the display is in the meter mode, you cannot see the change of voltage limit value when adjusting the knob. We recommend that you should set the display to “limit” mode to see the change of voltage limit value in the constant current mode whenever adjusting the knob.

- 5 Adjust the knob for the desired voltage limit.¹



Check that the knob is still selected for voltage control and the Lmt annunciator blinks. Adjust the knob for the desired voltage limit.

- 6 Adjust the knob for the desired output current.¹

Vol/Cur

Set the knob for current control. The second digit of the ammeter will be blinking. Adjust the knob to the desired current output.

- 7 Return to the meter mode.

Display Limit

Press the “Display Limit” key or let the display time-out after several seconds to return the meter mode. Notice that the Lmt annunciator turns off and the display returns to the meter mode. In the meter mode, the display shows the actual output voltage and current of the selected supply.

- 8 Verify that the power supply is in the constant current mode.

If you operate the +6V supply in the constant current (CC) mode, verify that CC and +6V annunciators are lit. If you operate the power supply for the +25V supply or the -25V supply, the +25V or -25V annunciator will turn on. If the CV annunciator is lit, choose a higher voltage limit.

NOTE

During actual CC operation, if a load change causes the voltage limit to be exceeded, the power supply will automatically crossover to constant voltage mode at the preset voltage limit and the output current will drop proportionately.

Front-Panel Operation

- ¹ You can use the resolution selection keys to move the blinking digit to the right or left when setting the voltage and current.

Tracking operation

The $\pm 25\text{V}$ supplies provide 0 to $\pm 25\text{ V}$ tracking outputs. In the track mode, two voltages of the $\pm 25\text{V}$ supplies track each other within $\pm(0.2\% \text{ output} + 20\text{ mV})$ for convenience in varying the symmetrical voltages needed by operational amplifiers and other circuits using balanced positive and negative inputs. The state of track mode is stored in volatile memory; the track is always off state when power has been off or after a remote interface reset.

To operate the power supply in the track mode, proceed as follows:

- 1 Set the +25V supply to the desired voltage as described in previous section “Constant voltage operation” on page 51 for detailed information.
- 2 Enable the track mode.

Track

The “Track” key must be depressed for at least 1 second to enable the track mode. When the track mode is first enabled, the -25V supply will be set to the same voltage level as the +25V supply. Once enabled, any change of the voltage level in either the +25V supply or the -25V supply will be reflected in other supply. The current limit is independently set for each of the +25V or the -25V supply and is not affected by the track mode.

- 3 Verify that the $\pm 25\text{V}$ supplies track each other properly.

You can verify that the voltage of the -25V supply tracks that of the +25V supply within $\pm(0.2\% \text{ of output} + 20\text{ mV})$ from the front-panel display by comparing the voltage values of the +25V supply and the -25V supply.

NOTE

In the track mode, if the CC annunciator is lit when the display is selected for the +25V supply, choose a higher current limit for the +25V supply. If the CC annunciator is lit when the display is selected for the -25V supply, choose a higher current limit for the -25V supply.

Storing and recalling operating states

You can store up to three different operating states in non-volatile memory. This also enables you to recall the entire instrument configuration with just a few key presses from the front panel.

The memory locations are supplied from the factory for front panel operation with the following states: *display and knob selection for +6V output; *RST values of voltage and current limits for three outputs; output disabled; and track off state.* *RST values for +6V supply are 0 V and 5 A and 0 V and 1 A for the ± 25 V supplies. The following steps show you how to store and recall an operating state.

- 1 Set up the power supply for the desired operating state.

The storage feature “remembers” the display and knob selection state, the limit values of voltage and current for three outputs, output on/off state, and track on/ off state.

- 2 Turn on the storage mode.

Three memory locations (numbered 1, 2 and 3) are available to store the operating states. The operating states are stored in non-volatile memory and are remembered when being recalled.

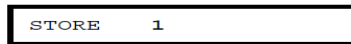

STORE 1

This message appears on the display for approximately 3 seconds.

- 3 Store the operating state in memory location “3”.

Turn the knob to the right to specify the memory location 3.

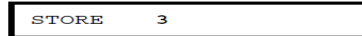

STORE 3

To cancel the store operation, let the display time-out after about 3 seconds or press any other function key except the “Store” key. The power supply returns to the normal operating mode and to the function pressed.

- 4 Save the operating state.

The operating state is now stored. To recall the stored state, go to the following steps.

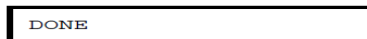

DONE

This message appears on the display for approximately 1 second.

- 5 Turn on the recall mode.

Memory location “1” will be displayed in the recall mode.



RECALL 1

This message appears on the display for approximately 3 seconds.

- 6 Recall the stored operating state.

Turn the knob to the right to change the displayed storage location to “3”.

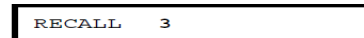

RECALL 3

If this setting is not followed within 3 seconds with a “Recall” key stroke, the power supply returns to normal operating mode and will not recall the instrument state 3 from memory.

- 7 Restore the operating state.

The power supply should now be configured in the same state as when you stored the state on the previous steps.

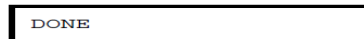

DONE

This message appears on the display for approximately 1 second.

Disabling the outputs

The outputs of the power supply can be disabled or enabled from the front panel using “Output On/Off” the key.

- When the power supply is in the “Off” state, the OFF annunciator turns on and the three outputs are disabled. The OFF annunciator turns off when the power supply returns to the “On” state. When the outputs are disabled, the voltage value is 0 volts and the current value is 0.05 amps.
- The output state is stored in volatile memory; the output is always disabled when power has been off or after a remote interface reset.

NOTE

While the outputs are disabled, the control knob and resolution selection keys are still working. If the display is in the meter mode, you cannot see the changes of output voltage and current settings on the display when turning the knob. To see or check the changes when the outputs are disabled, the display should be in the limit mode.

- Front-panel operation:
You can disable the outputs by pressing the “Output On/Off” key. This key toggles between the output Off and On states.
- Remote interface operation:
OUTPut {ON|OFF}
The outputs are disabled when the “OFF” parameter is selected and enabled when the “ON” is selected.

Knob locking

The knob locking function can be used to disable the knob, thereby preventing any unwanted changes during an experiment, or when you leave the power supply unattended.

To disable the knob, press the resolution selection key until the blinking digit disappears.

System-related operations

This section gives information on topics such as self-test, error conditions, and front panel display control. This information is not directly related to setting up the power supply but is an important part of operating the power supply.

Self-test

A power-on self-test occurs automatically when you turn on the power supply. This test assures you that the power supply is operational. This test does not perform the extensive set of tests that are included as part of the complete self-test described below. If the power-on self-test fails, the ERROR annunciator turns on.

- A complete self-test performs a series of tests and takes approximately 2 seconds to execute. If all tests pass, you can have a high confidence that the power supply is operational.
- If the complete self-test is successful, “PASS” is displayed on the front panel. If the self-test fails, “FAIL” is displayed and the ERROR annunciator turns on. See the Service Guide for instructions on returning the power supply to Keysight Technologies for service.
- Front-panel operation:
 - The complete self-test is enabled by pressing the “Recall” key (actually any front panel keys except the “Error” key) and the power-line switch simultaneously and then continuing to press the “Recall” key for 5 seconds. The complete self-test will be finished in 2 more seconds.
- Remote interface operation:
 - *TST?
 - Returns “0” if the complete self-test passes or “1” if it fails.

Error conditions

When the front-panel ERROR annunciator turns on, one or more command syntax or hardware errors have been detected. A record of up to 20 errors can be stored in the power supply's error queue. See “[Error Messages](#)” on page 137 for a complete listing of the errors.

- Errors are retrieved in first-in-first-out (FIFO) order. The first error returned is the first error that was stored. When you have read all errors from the queue,

the ERROR annunciator turns off. The power supply beeps once each time an error is generated.

- If more than 20 errors have occurred when you operate the power supply over the remote interface, the last error stored in the queue (the most recent error) is replaced with –350, “Queue overflow”. No additional errors are stored until you remove errors from the queue. If no errors have occurred when you read the error queue, the power supply responds with +0, “No error” over the remote interface or “NO ERRORS” from the front panel.
- The error queue is cleared when power has been off or after a *CLS (clear status) command has been executed. The *RST (reset) command does not clear the error queue.
- Front-panel operation:

If the ERROR annunciator is on, press the “Error” key repeatedly to read the errors stored in the queue. All errors are cleared when you read all errors.



- Remote interface operation:
 SYSTem:ERRor? Reads one error from the error queue
 Errors have the following format (the error string may contain up to 80 characters).
 -113, "Undefined header"

Display control

For security reasons, you may want to turn off the front-panel display. From the remote interface, you can display a 12-character message on the front panel.

The display can be enabled / disabled from the remote interface only.

- When the display is turned off, outputs are not sent to the display and all annunciators are disabled except the ERROR annunciator. Front-panel operation is otherwise unaffected by turning off the display.
- The display state is stored in volatile memory; the display is always enabled when power has been off, after a remote interface reset, or after returning to local from remote.
- You can display a message on the front panel by sending a command from the remote interface. The power supply can display up to 12 characters of the message on the front panel; any additional characters are truncated. Commas,

periods, and semicolons share a display space with the preceding character, and are not considered individual characters. When a message is displayed, outputs are not sent to the display.

- Sending a message to the display from the remote interface overrides the display state; this means that you can display a message even if the display is turned off.

The display state is automatically turned on when you return to the local (front panel) operation. Press the “Local” key to return to the local state from the remote interface.

- Remote interface operation:

DISPlay {OFF ON}	Disable / enable the display
DISPlay:TEXT <quoted string>	Display the string enclosed in quotes
DISPlay:TEXT:CLEAr	Clear the displayed message

The following statement shows how to display a message on the front panel from a Keysight Technologies controller.

```
"DISP:TEXT 'HELLO'"
```

Firmware revision query

The power supply has three microprocessors for control of various internal systems. You can query the power supply to determine which revision of firmware is installed for each microprocessor.

You can query the firmware revision from the remote interface only.

- The power supply returns four fields separated by commas and the fourth field is a revision code which contains three numbers. The first number is the firmware revision number for the main processor; the second is for the input/output processor; and the third is for the front-panel processor.

- Remote interface operation

```
*IDN? Returns "HEWLETT-PACKARD,E3631A,0,X.X-X.X-X.X"
```

Be sure to dimension a string variable with at least 40 characters.

SCPI language version

The power supply complies with the rules and regulations of the present version of SCPI (Standard Commands for Programmable Instruments). You can determine the SCPI version with which the power supply is in compliance by sending a command from the remote interface.

You can query the SCPI version from the remote interface only.

- Remote interface operation:

SYSTem:VERSion?

Returns a string in the form “YYYY.V” where the “Y’s” represent the year of the version, and the “V” represents a version number for that year (for example, 1995.0).

Remote interface configuration

Before you can operate the power supply over the remote interface, you must configure the power supply for the remote interface. This section gives information on configuring the remote interface. For additional information on programming the power supply over the remote interface, See Chapter 4 [Remote Interface Reference](#).

Remote interface selection

The power supply is shipped with both an GPIB (IEEE-488) interface and an RS-232 interface on the rear panel. Only one interface can be enabled at a time. The GPIB interface is selected when the power supply is shipped from the factory.

The remote interface can be selected from the front-panel only.

- The interface selection is stored in non-volatile memory, and does not change when power has been off or after a remote interface reset.
- If you select the GPIB interface, you must select a unique address for the power supply. The current address is displayed momentarily on the front panel when you turn on the power supply.¹
- Your GPIB bus controller has its own address. Be sure to avoid using the bus controller's address for any instrument on the interface bus. Keysight Technologies controllers generally use address "21".
- If you enable the RS-232 interface, you must select the baud rate and parity to be used. "RS-232" is displayed momentarily on the front panel when you turn on the power supply if you have selected this interface.²

¹ Refer to [GPIB interface configuration](#) for more information on connecting the power supply to a computer over the GPIB interface.

² Refer to [RS-232 interface configuration](#) for more information on connecting the power supply to a computer over the GPIB interface.

GPIB address

Each device on the GPIB (IEEE-488) interface must have a unique address. You can set the power supply's address to any value between 0 and 30. The current address is displayed momentarily on the front panel when you turn on the power supply. The address is set to "05" when the power supply is shipped from the factory.

The GPIB address can be set from the front-panel only.

- The address is stored in non-volatile memory, and does not change when power has been off or after a remote interface reset.
- Your GPIB bus controller has its own address. Be sure to avoid the bus controller's address for any instrument on the interface bus. Keysight Technologies controllers generally use address "21".

Baud rate selection (RS-232)

You can select one of six baud rates for RS-232 operation. The rate is set to 9600 baud when the power supply is shipped from the factory.

The baud rate can be set from the front-panel only.

- Select one of the following: 300, 600, 1200, 2400, 4800, **9600** baud. The factory setting is 9600 baud.
- The baud rate selection is stored in non-volatile memory, and does not change when power has been off or after a remote interface reset.

Parity selection (RS-232)

You can select the parity for RS-232 operation. The power supply is configured for no parity and 8 data bits when shipped from the factory.

The parity can be set from the front-panel only.

- Select one of the following: **None** (8 data bits), Even (7 data bits), or Odd (7 data bits). When you set the parity, you are indirectly setting the number of data bits.
- The parity selection is stored in non-volatile memory, and does not change when power has been off or after a remote interface reset.

To set the GPIB address

To configure the power supply for the GPIB interface, proceed as follows:

1 Turn on the remote configuration mode.

You will see the above message on the front-panel display if the power supply has not been changed from the default setting. If “RS-232” appears, choose “HPIB / 488” by turning the knob to the right.



2 Select the GPIB address.

The address is set to “05” when the power supply is shipped from the factory. Notice that a different GPIB address may appear if the power supply has been changed from the default setting.

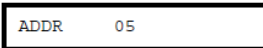

3 Turn the knob to change the GPIB address.

The displayed address is changed when turning the knob to the right or left.

4 Save the change and turn off the I/O configuration mode.

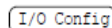
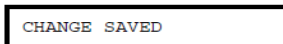

The address is stored in non-volatile memory, and does not change when power has been off or after a remote interface reset. The power supply displays a message to show that the change is now in effect. If the GPIB address is not changed, “NO CHANGE” will be displayed for one second.

NOTE

To cancel the I/O configuration mode without any changes during the GPIB address selection, press the “I/O Config” key until the “NO CHANGE” message is displayed.

To set the baud rate and parity (RS-232)

To configure the power supply for the RS-232 interface, proceed as follows:

- 1 Turn on the remote configuration mode.

HPIB / 488

I/O Config

You will see the above message on the display if the power supply has not been changed from the default setting.

Notice that if you changed the remote interface selection to RS-232 before, “RS-232” message will be displayed.

- 2 Choose the RS-232 interface.



RS-232

You can choose the RS-232 interface by turning the knob to the left.

- 3 Select the RS-232 interface and choose the baud rate.

9600 BAUD

I/O Config

The rate is set to 9600 baud when the power supply is shipped from the factory. Choose from one of the following by turning the knob to the right or left: 300, 600, 1200, 2400, 4800, or 9600 baud.

- 4 Save the change and choose the parity.

NONE 8 BITS

I/O Config

The power supply is configured for 8 data bits with no parity when shipped from the factory. Choose from one of the following by turning the knob to the right or left: None 8 Bits, Odd 7 Bits, or Even 7 Bits. When you set parity, you are indirectly setting the number of the data bits.

- 5 Save the change and turn off the I/O configuration mode.

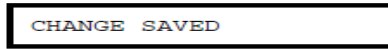
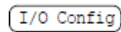
A rectangular box with a black border containing the text "CHANGE SAVED" in all caps.A rounded rectangular button with a black border containing the text "I/O Config" in all caps.

The RS-232 baud rate and parity selections are stored in non-volatile memory, and does not change when power has been off or after a remote interface reset. The power supply displays a message to show that the change is now in effect. If the baud rate and the parity are not changed, "NO CHANGE" will be displayed for one second.

NOTE

To cancel the I/O configuration mode without any changes during the baud rate and parity selection, press the "I/O Config" key until the "NO CHANGE" message is displayed.

GPIB interface configuration

The GPIB connector on the rear panel connects your power supply to the computer and other GPIB devices. Chapter 1 lists the cables that are available from Keysight Technologies. An GPIB system can be connected together in any configuration (star, linear, or both) as long as the following rules are observed:

- The total number of devices including the computer is no more than 15.
- The total length of all the cables used is no more than 2 meter times the number of devices connected together, up to a maximum of 20 meters.

NOTE

IEEE-488 states that you should exercise caution if your individual cable lengths exceed 4 meters.

Do not stack more than three connector blocks together on any GPIB connector. Make sure that all connectors are fully seated and that the lock screws are firmly finger tightened.

RS-232 interface configuration

You connect the power supply to the RS-232 interface using the 9-pin (DB-9) serial connector on the rear panel. The power supply is configured as a DTE (Data Terminal Equipment) device. For all communications over the RS-232 interface, the power supply uses two handshake lines: DTR (Data Terminal Ready, on pin 4) and DSR (Data Set Ready, on pin 6). The following sections contain information to help you use the power supply over the RS-232 interface. The programming commands for RS-232 are explained in Chapter 4, [RS-232 interface configuration](#).

RS-232 configuration overview

Configure the RS-232 interface using the parameters shown below. Use the frontpanel “I/O Config” key to select the baud rate, parity, and number of data bits (see [To set the baud rate and parity \(RS-232\)](#) for more information to configure from the front panel).

Baud rate:	300, 600, 1200, 2400, 4800, or 9600 baud (<i>factory setting</i>)
	None / 8 data bits (<i>factory setting</i>)
Parity and data bits:	Even / 7 data bits, or Odd / 7 data bits
Number of start bits:	1 bit (<i>fixed</i>)
Number of stop bits:	2 bit (<i>fixed</i>)

RS-232 data frame format

A character frame consists of all the transmitted bits that make up a single character. The frame is defined as the characters from the start bit to the last stop bit, inclusively. Within the frame, you can select the baud rate, number of data bits, and parity type. The power supply uses the following frame formats for seven and eight data bits.

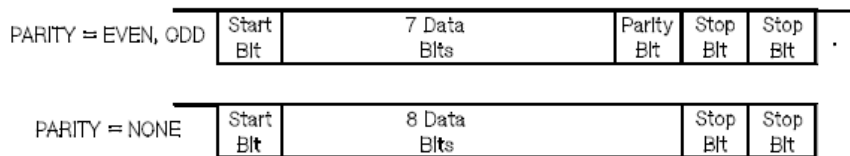

Connection to a computer or terminal

To connect the power supply to a computer or terminal, you must have the proper interface cable. Most computers and terminals are DTE (Data Terminal equipment) devices. Since the power supply is also a DTE device, you must use a DTE-to-DTE interface cable. These cables are also called null-modem, modem-eliminator, or crossover cables.

The interface cable must also have the proper connector on each end and the internal wiring must be correct. Connectors typically have 9 pins (DB-9 connector) or 25 pins (DB-25 connector) with a “male” or “female” pin configuration. A male connector has pins inside the connector shell and a female connector has holes inside the connector shell.

If you cannot find the correct cable for your configuration, you may have to use a wiring adapter. If you are using a DTE-to-DTE cable, make sure the adapter is a “straight-through” type. Typical adapters include gender changers, null-modem adapters, and DB-9 to DB-25 adapters.

The cable and adapter diagrams shown below can be used to connect the power supply to most computers or terminals. If your configuration is different than those described, order the Keysight 34399A, 34399A Adapter Kit. This kit contains adapters for connection to other computers, terminals, and modems. Instructions and pin diagrams are included with the adapter kit.

DB-9 Serial Connection If your computer or terminal has a 9-pin serial port with a male connector, use the null-modem cable included with the Keysight 34398A Cable Kit. This cable has a 9-pin female connector on each end. The cable pin diagram is shown below.

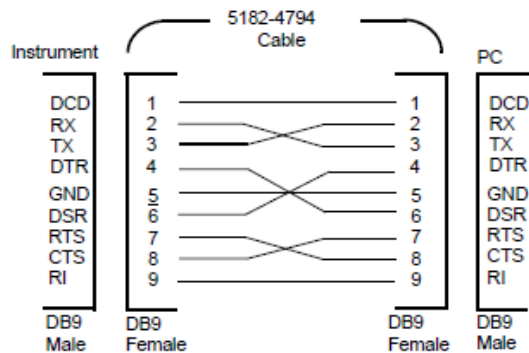

DB-25 Serial Connection If your computer or terminal has a 25-pin serial port with a male connector, use the null-modem cable and 25-pin adapter included with the Keysight 34398A Cable Kit. The cable and adapter pin diagram are shown below.

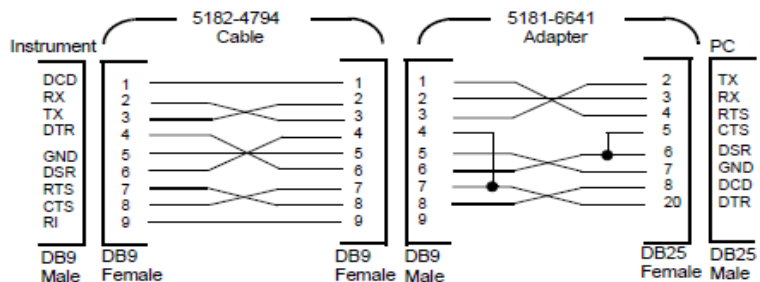

DTR/DSR handshake protocol

The power supply is configured as a DTE (Data Terminal Equipment) device and uses the DTR (Data Terminal Ready) and DSR (Data Set Ready) lines of the RS-232 interface to handshake. The power supply uses the DTR line to send a hold-off signal. The DTR line must be TRUE before the power supply will accept data from the interface. When the power supply sets the DTR line FALSE, the data must cease within 10 characters.

To disable the DTR/DSR handshake, do not connect the DTR line and tie the DSR line to logic TRUE. If you disable the DTR/DSR handshake, also select a slower baud rate to ensure that the data is transmitted correctly.

The power supply sets the DTR line FALSE in the following cases:

- 1 When the power supply's input buffer is full (when approximately 100 characters have been received), it sets the DTR line FALSE (pin 4 on the RS-232 connector). When enough characters have been removed to make space in the input buffer, the power supply sets the DTR line TRUE, unless the second case (see next) prevents this.
- 2 When the power supply wants to "talk" over the interface (which means that it has processed a query) and has received a <new line> message terminator, it will set the DTR line FALSE. This implies that once a query has been sent to the

power supply, the bus controller should read the response before attempting to send more data. It also means that a <new line> must terminate the command string. After the response has been output, the power supply sets the DTR line TRUE again, unless the first case (see above) prevents this.

The power supply monitors the DSR line to determine when the bus controller is ready to accept data over the interface. The power supply monitors the DSR line (pin 6 on the RS-232 connector) before each character is sent. The output is suspended if the DSR line is FALSE. When the DSR line goes TRUE, transmission will resume.

The power supply holds the DTR line FALSE while output is suspended. A form of interface deadlock exists until the bus controller asserts the DSR line TRUE to allow the power supply to complete the transmission. You can break the interface deadlock by sending the <Ctrl-C> character, which clears the operation in progress and discards pending output (this is equivalent to the IEEE-488 device clear action).

For the <Ctrl-C> character to be recognized reliably by the power supply while it holds DTR FALSE, the bus controller must first set DSR FALSE.

RS-232 troubleshooting

Here are a few things to check if you are having problems communicating over the RS-232 interface. If you need additional help, refer to the documentation that came with your computer.

- Verify that the power supply and your computer are configured for the same baud rate, parity, and number of data bits. Make sure that your computer is set up for 1 start bit and 2 stop bits (these values are fixed on the power supply).
- Make sure to execute the SYSTem:REMOte command to place the power supply in the remote mode.
- Verify that you have connected the correct interface cable and adapters. Even if the cable has the proper connectors for your system, the internal wiring may be incorrect. The Keysight 34398A Cable Kit can be used to connect the power supply to most computers or terminals.
- Verify that you have connected the interface cable to the correct serial port on your computer (COM1, COM2, etc.).

Calibration overview

This section gives an overview of the calibration features of the power supply. For more detailed discussion of the calibration procedures, see the Service Guide.

Calibration Security

This feature allows you to enter a security code to prevent accidental or unauthorized calibrations of the power supply. When you first receive your power supply, it is secured. Before you can calibrate the power supply, you must unsecure it by entering the correct security code.

- The security code is set to “HP003631” when the power supply is shipped from the factory. The security code is stored in non-volatile memory, and does not change when power has been off or after a remote interface reset.
- To secure the power supply from the remote interface, the security code may contain up to 12 alphanumeric characters as shown below. The first character must be a letter, but the remaining characters can be letters or numbers. You do not have to use all 12 characters but the first character must always be a letter.

A _____ (12 characters)

- To secure the power supply from the remote interface so that it can be unsecured from the front panel, use the eight-character format shown below. The first two characters must be “H P” and the remaining characters must be numbers. Only the last six characters are recognized from the front panel, but all eight characters are required. To unsecure the power supply from the front panel, omit the “H P” and enter the remaining numbers as shown on the following.

HP_____ (8 characters)

If you forget your security code, you can disable the security feature by adding a jumper inside the power supply, and then entering a new code. See the Service Guide for more information.

To Unsecure for Calibration You can unsecure the power supply for calibration either from the front panel or over the remote interface. The power supply is secured when shipped from the factory, and the security code is set to “HP003631”.

- Front-Panel Operation



SECURED

If the power supply is secured, you will see the above message for one second by holding the “Calibrate” key for 5 seconds when you turn on the power supply. To unsecure the power supply, press the “Secure” key after the “CAL MODE” message is displayed in the calibration mode, enter the security code using the knob and resolution selection keys, and then press the “Secure” key.

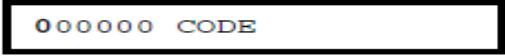

000000 CODE

When you press the “Secure” key to save the change, you will see the message below for one second if the security code is correct. The unsecured setting is stored in nonvolatile memory, and does not change when power has been off or after a remote interface reset. To exit the calibration mode, turn the power off and on.

Notice that if the security is incorrect, the power supply returns to the code entering mode for you to enter the correct code.



UNSECURED

- Remote Interface Operation:

CALibrate:SECure:STATe, {OFF|ON}, <code>

To unsecure the power supply, send the above command with the same code used to secure. For example,

"CAL:SEC:STAT OFF, HP003631"

To Secure Against Calibration You can secure the power supply against calibration either from the front panel or over the remote interface. The power supply is secured when shipped from the factory, and the security code is set to “HP003631”.

Be sure to read the security code rules on “[Calibration Security](#)” on page 76 before attempting to secure the power supply.

– Front-Panel Operation:

To change the security code, first make sure that the power supply is unsecured. Press the “Secure” key after the “CAL MODE” message is displayed in the calibration mode, enter the new security code using the knob and resolution selection keys, then press the “Secure” key.

Changing the code from the front panel also changes the code required from the remote interface.

– Remote Interface Operation:

CALibrate:SECure:CODE <*new code*>

To change the security code, first unsecure the power supply using the old security code. Then, enter the new code. For example,

"CAL:SEC:STAT OFF, HP003631"	Unsecure with old code
"CAL:SEC:CODE ZZ001443"	Enter new code
"CAL:SEC:STAT ON, ZZ00143"	Secure with new code

Calibration count

You can determine the number of times that your power supply has been calibrated. Your power supply was calibrated before it left the factory. When you receive your power supply, read the count to determine its initial value.

The calibration count feature can be performed from the remote interface only.

- The calibration count is stored in non-volatile memory, and does not change when power has been off or after a remote interface reset.
- The calibration count increments up to a maximum of 32,767 after which it wraps around to 0. Since the value increments by one for each calibration point, a complete calibration will increase the value by 6 counts.

- Remote Interface Operation:
CALibrate:COUnT?

Calibration message

You can use the calibration message feature to record calibration information about your power supply. For example, you can store such information as the last calibration date, the next calibration due date, the power supply's serial number, or even the name and phone number of the person to contact for a new calibration.

You can record and read information in the calibration message from the remote interface only.

- The power supply should be unsecured before sending a calibration message.
- The calibration message may contain up to 40 characters.
- The calibration message is stored in non-volatile memory, and does not change when power has been off or after a remote interface reset.
- Remote Interface Operation:

CALibrate:STRing <quoted string> Store the cal message

The following command string shows how to store a calibration message.

```
"CAL:STR 'CAL 05-1-95'"
```

THIS PAGE HAS BEEN INTENTIONALLY LEFT BLANK.

4 Remote Interface Reference

- SCPI command summary 83
- Simplified Programming Overview 89
- Using the APPLy command 92
- Output setting and operation commands 93
- Triggering commands 99
- System-Related Commands 103
- Calibration commands 106
- RS-232 Interface Commands 108
- The SCPI status registers 109
- Status reporting commands 120
- An introduction to the SCPI language 125
- SCPI Conformance Information 131
- IEEE-488 Conformance information 136

If you are a first-time user of the SCPI language, you may want to refer to these sections to become familiar with the language before attempting to program the power supply.

SCPI command summary

This section summarizes the SCPI (Standard Commands for Programmable Instruments) commands available to program the power supply over the remote interface. Refer to the later sections in this chapter for more complete details on each command.

Throughout this manual, the following conventions are used for SCPI command syntax.

- Square brackets ([]) indicate optional keywords or parameters.
- Braces ({ }) enclose parameters within a command string.
- Triangle brackets (< >) indicate that you must substitute a value or a code for the enclosed parameter.
- A vertical bar (|) separates one of two or more alternative parameters.

First-time SCPI users, see **Chapter 4: An introduction to the SCPI language**

Output setting and operation commands

APPLy

{P6V|P25V|N25V}[,{<voltage>|DEF|MIN|MAX}][,{<current>|DEF|MIN|MAX}]

APPLy? [{P6V|P25V|N25V}]

INSTrument

[:SElect] {P6V|P25V|N25V}

[:SElect]?

:NSElect {1|2|3}

:NSElect?

:COUple[:TRIGger] {ALL|NONE|<list>}

:COUple[:TRIGger]?

MEASure

:CURRent[:DC]? [{P6V|P25V|N25V}]

[:VOLTagE][:DC]? [{P6V|P25V|N25V}]

OUTPut

[:STATe] {OFF|ON}

[:STATe]?

:TRACk[:STATe] {OFF|ON}

:TRACk[:STATe]?

[SOURce:]

CURRent[:LEVel][:IMMediate][:AMPLitude] {<current>[MIN|MAX]}

CURRent[:LEVel][:IMMediate][:AMPLitude]?[MIN|MAX]

CURRent[:LEVel]:TRIGgered[:AMPLitude] {<current>[MIN|MAX]}

CURRent[:LEVel]:TRIGgered[:AMPLitude]? [MIN|MAX]

VOLTagE[:LEVel][:IMMediate][:AMPLitude] {<voltage>[MIN|MAX]}

VOLTagE[:LEVel][:IMMediate][:AMPLitude]?[MIN|MAX]

VOLTagE[:LEVel]:TRIGgered[:AMPLitude] {<voltage>[MIN|MAX]}

VOLTagE[:LEVel]:TRIGgered[:AMPLitude]? [MIN|MAX]

Triggering commands

INITiate [:IMMediate]
 TRIGger[:SEQuence]
 :DElay {<seconds>|MIN|MAX}
 :DElay?
 :SOURce {BUS|IMM}
 :SOURce?
 *TRG

System-related commands

DISPlay[:WINDow]
 [:STATe] {OFF|ON}
 [:STATe]?
 :TEXT[:DATA] <quoted string>
 :TEXT[:DATA]?
 :TEXT:CLEar
 SYSTem
 :BEEPer[:IMMediate]
 :ERRor?
 :VERSion?
 *IDN?
 *RST
 *TST?
 *SAV {1|2|3}
 *RCL {1|2|3}

Calibration commands

CALibration

:COUNT?
:CURRENT[:DATA] <numeric value>
:CURRENT:LEVel {MIN|MAX}
:SECure:CODE <new code>
:SECure:STATe {OFF|ON},<code>
:SECure:STATe?
:STRing <quoted string>
:STRing?
:VOLTage[:DATA] <numeric value>
:VOLTage:LEVel {MIN|MAX}

Status reporting commands

STATus:QUEStionable

[:EVENT]?
:ENABle <enable value>
:ENABle?
:INSTrument[:EVENT]?
:INSTrument:ENABle <enable value>
:INSTrument:ENABle?
:INSTrument:ISUMmary<n>[:EVENT]?
:INSTrument:ISUMmary<n>:CONDition?
:INSTrument:ISUMmary<n>:ENABle <enable value>
:INSTrument:ISUMmary<n>:ENABle?

SYSTem:ERRor?

*CLS

*ESE <enable value>

*ESE?
*ESR?
*OPC
*OPC?
*PSC {0|1}
*PSC?
*SRE <enable value>
*SRE?
*STB?
*WAI

RS-232 interface commands

SYSTem

:LOCal

:REMOte

:RWLOCK

IEEE-488.2 common commands

*CLS
*ESE <enable value>
*ESE?
*ESR?
*IDN?
*OPC
*OPC?
*PSC {0|1}
*PSC?

Remote Interface Reference

*RST

*SAV {1|2|3}

*RCL {1|2|3}

*SRE <enable value>

*SRE?

*STB?

*TRG

*TST?

*WAI

Simplified Programming Overview

This section gives an overview of the basic techniques used to program the power supply over the remote interface. This section is only an overview and does not give all of the details you will need to write your own application programs. Refer to the remainder of this chapter and also chapter 6, Application Programs, for more details and examples. Also refer to the programming reference manual that came with your computer for details on outputting command strings and entering data.

Using the APPLy command

The APPLy command provides the most straightforward method to program the power supply over the remote interface. For example, the following statement executed from your computer will set the +6V supply to an output of 3 V rated at 1 A:

```
"APPL P6V, 3.0, 1.0"
```

Using the low-level commands

Although the APPLy command provides the most straightforward method to program the power supply, the low-level commands give you more flexibility to change individual parameters. For example, the following statements executed from your computer will set the +6V supply to an output of 3 V rated at 1 A:

"INST P6V"	Select +6V output
"VOLT 3.0"	Set output voltage to 3.0 V
"CURR 1.0"	Set output current to 1.0 A

Reading a query response

Only the query commands (commands that end with “?”) will instruct the power supply to send a response message. Queries return either output values or internal instrument settings. For example, the following statements executed from your computer will read the power supply's error queue and print the most recent error:

dimension statement	Dimension string array (80 elements)
"SYST:ERR?"	Read error queue
bus enter statement	Enter error string into computer
print statement	Print error string

Selecting a trigger source

The power supply will accept a “bus” (software) trigger or an immediate internal trigger as a trigger source. By default, the “BUS” trigger source is selected. If you want the power supply to use an immediate internal trigger, you must select “IMMEDIATE”. For example, the following statements executed from your computer will set the +6V supply to an output of 3V/1A immediately:

"INST P6V"	Select the +6V output
"VOLT:TRIG 3.0"	Set the triggered voltage level to 3.0 V
"CURR:TRIG 1.0"	Set the triggered current level to 1.0 A
"TRIG:SOUR IMM"	Select the immediate trigger as a source
"INIT"	Cause the trigger system to initiate

Programming ranges and output identifiers

Output setting commands require a parameter for programming ranges and an output name or an output number as the identifier of each output and most queries will return a parameter. The programming range for a parameter varies according to the selected output of the power supply. The following table lists the programming ranges, output names, and output numbers for each output.

Refer to this table to identify parameters when programming the power supply.

Table 4-1 Keysight E3631A Programming Ranges and Output Identifiers

		Output		
		+6V output	+25V output	-25V output
Voltage	Programming range	0 to 6.18 V	0 to +25.75 V	0 to -25.75 V
	MAX value	6.18 V	25.75 V	-25.75 V
	MIN value	0 V	0 V	0 V
	*RST value (DEFAult value)	0 V	0 V	0 V
Current	Programming range	0 to 5.15 A	0 to 1.03 A	0 to 1.03 A
	MAX value	5.15 A	1.03 A	1.03 A
	MIN value	0 A	0 A	0 A
	*RST value (DEFAult value)	5 A	1 A	1 A
Output identifier		P6V	P25V	N25V
Output number		1	2	3

Using the APPLy command

The APPLy command provides the most straightforward method to program the power supply over the remote interface. You can select the specific output, output voltage, and output current all in one command.

APPLy

{P6V|P25V|N25V}[,{<voltage>|DEF|MIN|MAX}][,{<current>|DEF|MIN|MAX}]

{P6V|P25V|N25V}[,{<voltage>|DEF|MIN|MAX}][,{<current>|DEF|MIN|MAX}] This command is combination of INSTRument:SElect, [SOURce:] VOLTage, and [SOURce:]CURRent commands. The values of voltage and the current of the specified output are changed as soon as the command is executed.

You can identify each output by the output name (P6V, P25V or N25V) as described in Table 4-1. For the voltage and current parameters of the APPLy command, the ranges depend on the output currently selected. You can substitute “MINimum”, “MAXimum”, or “DEFault” in place of a specific value for the voltage and current parameters. MIN selects the lowest voltage and current values allowed for the selected output. MAX selects the highest voltage and current values allowed. The default voltage values are 0 volts for all outputs. The default current values are 5 A for +6V output and 1 A for \pm 25V outputs. The default voltage and current values are exactly the same as the *RST values. See [Table 4-1](#) for details of parameters. If you specify only one value for the parameter, the power supply regards it as voltage setting value. If you do not specify any value for the parameter, the APPLy command only selects the output specified and acts as the INSTRument command.

APPLy? [{P6V|P25V|N25V}]

This command queries the power supply's present voltage and current values for each output and returns a quoted string. The voltage and current are returned in sequence as shown in the sample string below (the quotation marks are returned as part of the string). If any output identifier is not specified, the voltage and the current of the currently selected output are returned.

```
"5.000000,1.000000"
```

In the above string, the first number 5.000000 is the voltage limit value and the second number 1.000000 is the current limit value for the specified output.

Output setting and operation commands

This section describes the low-level commands used to program the power supply. Although the APPLY command provides the most straightforward method to program the power supply, the low-level commands give you more flexibility to change individual parameters.

See “[Programming ranges and output identifiers](#)” on page 91 for programming ranges, output identifiers, and MIN / MAX values in the following commands.

Output selection commands

INSTRument[:SElect] {P6V|P25V|N25V}

This command selects the output to be programmed among three outputs by the output identifier. The outputs of the power supply are considered three logical instruments. The INSTRument command provides a mechanism to identify and select an output. When one output is selected, the other outputs are unavailable for programming until selected. The commands which are affected by the INSTRument command are output setting commands (SOURce), measurement commands (MEASure), and calibration commands (CALibration). “P6V” is the identifier for +6V output, “P25V” is for +25V output and “N25V” is for -25V output.

INSTRument[:SElect]?

This query returns the currently selected output by the INSTRument [:SElect] or INSTRument:NSElect command. The returned parameter is “P6V”, “P25V”, or “N25V”.

INSTRument:NSElect {1|2|3}

This command selects the output to be programmed among three outputs by a numeric value instead of the output identifier used in the INSTRument [:SElect] command. “1” selects +6V output, “2” selects +25V output, and “3” selects -25V output.

INSTRument:NSElect?

This query returns the currently selected output by the INSTRument:NSElect or INSTRument[:SElect] command. The returned parameter is “1” for +6V output, “2” for +25V output or “3” for -25V output.

INSTrument:COUPle[:TRIGger] {ALL|NONE |<list>}

This command defines a coupling between various logical outputs of the power supply. The couple command consists of an optional subsystem node followed by a single parameter. The only valid parameter for the optional subsystem node is TRIGger subsystem. If no node follows the couple command, TRIGger subsystem is assumed to be coupled.

The parameter indicates to which logical outputs the specified coupling is to apply. "ALL" indicates that specified coupling is to apply to all outputs. "NONE" indicates that specified coupling is to be removed. A list of outputs specifies a particular set of logical outputs to be coupled. At *RST, all outputs are uncoupled. Notice that TRACk must be off before the $\pm 25\text{V}$ supplies can be coupled.

INST:COUP**Example (1)**

The following program segment shows how to use the INSTrument:COUPle command to couple two outputs between the +6V and the +25V outputs with voltage and current triggered levels. The power supply is set to the newly programmed values as set by the VOLTage:TRIGgered and CURRent:TRIGgered commands.

"INST:SEL P6V"	Select the +6V output
"VOLT:TRIG 5"	Set triggered level to 5 V
"CURR:TRIG 3"	Set triggered level to 3 A
"INST:SEL P25V"	Select the +25V output
"VOLT:TRIG 20"	Set triggered level to 20 V
"CURR:TRIG 0.5"	Set triggered level to 0.5 A
"INST:COUP P6V,P25V"	Couple the +6V and +25V supply
"TRIG:SOUR IMM"	Set trigger to immediate
"INIT"	Trigger the power supply to output the trigger values for the +6V and the +25V supplies

NOTE

If you select the bus trigger source in the above program (see **Trigger source choices** for the detailed information), you must send the *TRG or Group Execute Trigger (GET) command to start the trigger action after sending the INITiate command.

INSTRument:COUPlE[:TRIGger]?

This query returns the currently coupled output. Returns “ALL”, “NONE”, or a list. If any output is not coupled, “NONE” is returned. If all of three outputs are coupled, “ALL” is returned. If a list of outputs is coupled, the list is returned.

Measurement commands**MEASure:CURRent[:DC]? [{P6V|P25V|N25V}]**

This command queries the current measured at the output terminals of the power supply. The physical outputs of measurement are specified by the output identifier. If any output identifier is not specified, the current of the currently selected output is returned.

MEASure[:VOLTage][:DC]? [{P6V|P25V|N25V}]

This command queries the voltage measured at the output terminals of the power supply. If any output identifier is not specified, the voltage of the currently selected output is returned.

Output on/off and tracking operation commands

OUTPut[:STATe] {OFF|ON}

This command enables or disables all three outputs of the power supply. The state of the disabled outputs is a condition of less than 0.6 volts of opposite polarity with no load and less than 60 mA of opposite direction with a short circuit. At *RST, the output state is off.

OUTPut[:STATe]?

This command queries the output state of the power supply. The returned value is “0” (OFF) or “1” (ON).

OUTPut:TRACk[:STATe] {OFF|ON}

This command enables or disables the power supply to operate in the track mode. When the track mode is first enabled, the -25V supply will be set to the same voltage level as the +25V supply. Once enabled, any change of the programmed voltage level in either +25V supply or -25V supply will be reflected in the other supply. The TRACk OFF command returns the power supply to the non-track mode. The $\pm 25V$ supplies must not be coupled to enable “Track”. At *RST, the track mode is disabled.

OUTPut:TRACk[:STATe]?

This command queries the track mode state of the power supply. The returned value is “0” (OFF) or “1” (ON).

Output setting commands

[SOURce:]CURRent[:LEVel][:IMMediate][:AMPLitude]

{<current>|MINimum|MAXimum}

This command directly programs the immediate current level of the power supply. The immediate level is the current limit value of the output selected with the INSTRument command.

[SOURce:]CURRent[:LEVel][:IMMediate][:AMPLitude]?

[MINimum|MAXimum]

This query returns the presently programmed current limit level of the selected output. CURRent? MAXimum and CURRent? MINimum return the maximum and minimum programmable current levels of the selected output.

[SOURce:]CURRent[:LEVel]:TRIGgered[:AMPLitude]

{<current>| MINimum|MAXimum}

This command programs the pending triggered current level of the power supply. The pending triggered current level is a stored value that is transferred to the output terminals when a trigger occurs. A pending triggered level is not affected by subsequent CURRent commands.

[SOURce:]CURRent[:LEVel]:TRIGgered[:AMPLitude]?

[MINimum|MAXimum]

This query returns the presently programmed triggered current level. If no triggered level is programmed, the CURRent level is returned. CURRent :TRIGgered? MAXimum and CURRent:TRIGgered? MINimum return the maximum and minimum programmable triggered current levels.

VOLTage[:LEVel][:IMMediate][:AMPLitude]

{<voltage>| MINimum|MAXimum}

This command directly programs the immediate voltage level of the power supply. The immediate level is the voltage limit value of the selected output with the INSTRument command.

[SOURce:]VOLTage[:LEVel][:IMMediate][:AMPLitude]?

[MINimum|MAXimum]

This query returns the presently programmed voltage limit level of the selected output. VOLTage? MAXimum and VOLTage? MINimum return the maximum and minimum programmable voltage levels of the selected output.

[SOURce:]VOLTage[:LEVel]:TRIGgered[:AMPLitude]?

{<voltage>| MINimum|MAXimum}

This command programs the pending triggered voltage level of the power supply. The pending triggered voltage level is a stored value that is transferred to the output terminals when a trigger occurs. A pending triggered level is not affected by subsequent VOLTage commands.

[SOURce:]VOLTage[:LEVel]:TRIGgered[:AMPLitude]?

[MINimum|MAXimum]

This query returns the presently programmed triggered voltage level. If no triggered level is programmed, the VOLTage level is returned. VOLTage:TRIGgered? MAXimum and VOLTage:TRIGgered? MINimum return the maximum and minimum programmable triggered voltage levels.

Triggering commands

The power supply's triggering system allows a change in voltage and current when receiving a trigger, to select a trigger source, and to insert a trigger. Triggering the power supply is a multi-step process.

- First, you must select an output with the INSTRUMENT:SElect command and then configure the power supply for the triggered output level by using CURRent:TRIGgered and VOLTage:TRIGgered commands.
- Then, you must specify the source from which the power supply will accept the trigger. The power supply will accept a bus (software) trigger or an immediate trigger from the remote interface.
- Then, you can set the time delay between the detection of the trigger on the specified trigger source and the start of any corresponding output change. Notice that the time delay is valid for only the bus trigger source.
- Finally, you must provide an INITiate[:IMMediate]command. If the IMMEDIATE source is selected, the selected output is set to the triggered level immediately. But if the trigger source is the bus, the power supply is set to the triggered level after receiving the Group Execute Trigger (GET) or *TRG command.

Trigger source choices

You must specify the source from which the power supply will accept a trigger. The trigger is stored in volatile memory; the source is set to bus when the power supply has been off or after a remote interface reset.

Bus (Software) Triggering

- To select the bus trigger source, send the following command.

```
TRIGger:SOURce BUS
```

- To trigger the power supply from the remote interface (GPIB or RS-232) after selecting the bus source, send the *TRG (trigger) command. When the *TRG is sent, the trigger action starts after the specified time delay if any delay is given.
- You can also trigger the power supply from the GPIB interface by sending the IEEE-488 Group Execute Trigger (GET) message. The following statement shows how to send a GET from a Keysight Technologies controller.

```
TRIGGER 705 (group execute trigger)
```

- To ensure synchronization when the bus source is selected, send the *WAI (wait) command. When the *WAI command is executed, the power supply waits for all pending operations to complete before executing any additional commands. For example, the following command string guarantees that the first trigger is accepted and is executed before the second trigger is recognized.

```
TRIG:SOUR BUS;*TRG;*WAI;*TRG;*WAI
```

- You can use the *OPC? (operation complete query) command or the *OPC (operation complete) command to signal when the operation is complete. The *OPC? command returns “1” to the output buffer when the operation is complete. The *OPC command sets the “OPC” bit (bit 0) in the Standard Event register when the operation is complete.

Immediate triggering

- To select the immediate trigger source, send the following command.

```
TRIGger:SOURce IMM
```

- When the IMMEDIATE is selected as a trigger source, an INITiate command immediately transfers the VOLTage:TRIGgered[:AMPLitude] and CURRent:TRIGgered[:AMPLitude] values to VOLTage[:LEVel][:IMMEDIATE][:AMPLitude] and CURRent[:LEVel][:IMMEDIATE][:AMPLitude] values. Any delay is ignored.

Triggering commands**INITiate[:IMMEDIATE]**

This command causes the trigger system to initiate. This command completes one full trigger cycle when the trigger source is an immediate and initiates the trigger subsystem when the trigger source is bus.

TRIGger[:SEQUENCE]:DELAY{<seconds>| MINimum|MAXimum}

This command sets the time delay between the detection of an event on the specified trigger source and the start of any corresponding trigger action on the power supply output. Select from 0 to 3600 seconds. MIN = 0 seconds. MAX = 3600 seconds. At *RST , this value is set to 0 seconds.

TRIGger[:SEQUENCE]:DELAY?

This command queries the trigger delay.

TRIGger[:SEQUENCE]:SOURCE {BUS|IMMEDIATE}

This command selects the source from which the power supply will accept a trigger. The power supply will accept a bus (software) trigger or an internal immediate trigger. At *RST, the bus trigger source is selected.

TRIGger[:SEQUENCE]:SOURCE?

This command queries the present trigger source. Returns “BUS” or “IMM”.

***TRG**

This command generates a trigger to the trigger subsystem that has selected a bus (software) trigger as its source (TRIGger:SOURce BUS). The command has the same effect as the Group Execute Trigger (GET) command. For RS-232 operation, make sure the power supply is in the remote interface mode by sending the SYSTem:REMOte command first.

System-Related Commands

DISPlay[:WINDow][:STATe] {OFF|ON}

This command turns the front-panel display off or on. When the display is turned off, outputs are not sent to the display and all annunciators are disabled except the ERROR annunciator.

The display state is automatically turned on when you return to the local mode. Press the “Local” key to return to the local state from the remote interface.

DISPlay[:WINDow][:STATe]?

This command queries the front-panel display setting. Returns “0” (OFF) or “1” (ON).

DISPlay[:WINDow]:TEXT[:DATA] <quoted string>

This command displays a message on the front panel. The power supply will display up to 12 characters in a message; any additional characters are truncated. Commas, periods, and semicolons share a display space with the preceding character, and are not considered individual characters.

DISPlay[:WINDow]:TEXT[:DATA]?

This command queries the message sent to the front panel and returns a quoted string.

DISPlay[:WINDow]:TEXT:CLEAr

This command clears the message displayed on the front panel.

SYSTem:BEEPer[:IMMediate]

This command issues a single beep immediately.

SYSTem:ERRor?

This command queries the power supply's error queue. When the front-panel ERROR annunciator turns on, one or more command syntax or hardware errors have been detected. Up to 20 errors can be stored in the error queue. See [Error Messages](#) in chapter 5.

- Errors are retrieved in first-in-first-out (FIFO) order. The first error returned is the first error that was stored. When you have read all errors from the queue, the ERROR annunciator turns off. The power supply beeps once each time an error is generated.

- If more than 20 errors have occurred, the last error stored in the queue (the most recent error) is replaced with -350, "Queue overflow". No additional errors are stored until you remove errors from the queue. If no errors have occurred when you read the error queue, the power supply responds with +0, "No error".
- The error queue is cleared when power has been off or after a *CLS (clear status) command has been executed. The *RST (reset) command does not clear the error queue.

SYSTEM:VERSion?

This command queries the power supply to determine the present SCPI version. The returned value is of a string in the form YYYY.V where the "Y's" represent the year of the version, and the "V" represents a version number for that year (for example, 1995.0).

***IDN?**

This query command reads the power supply's identification string. The power supply returns four fields separated by commas. The first field is the manufacturer's name, the second field is the model number, the third field is not used (always "0"), and the fourth field is a revision code which contains three numbers. The first number is the firmware revision number for the main power supply processor; the second is for the input/output processor; and the third is for the front-panel processor.

The command returns a string with the following format (be sure to dimension a string variable with at least 40 characters):

HEWLETT-PACKARD,E3631A,0,X.X-X.X-X.X

***RST**

This command resets the power supply to its power-on state as follows:

Command	State
CURR[:LEV][:IMM]	Output dependent value*
CURR[:LEV]:TRIG	Output dependent value*
DISP[:STAT]	ON

INST[:SEL]	P6V
INST:COUP	NONE
OUTP[:STAT]	OFF
OUTP:TRAC	OFF
TRIG:DEL	0
TRIG:SOUR	BUS
VOLT[:LEV][:IMM]	0
VOLT[:LEV]:TRIG	0

**The reset operation sets the current of +6V output to 5 A and the current of +25V and -25V outputs to 1 A.*

***TST?**

This query performs a complete self-test of the power supply. Returns “0” if the selftest passes or “1” or any non-zero value if it fails. If the self-test fails, an error message is also generated with additional information on why the test failed.

***SAV { 1|2|3 }**

This command stores the present state of the power supply to the specified location in non-volatile memory. Three memory locations (numbered 1, 2 and 3) are available to store operating states of the power supply. The state storage feature “remembers” the states or values of INST[:SEL], VOLT[:IMM], CURR[:IMM], OUTP[:STAT], OUTP:TRAC, TRIG:SOUR, and TRIG:DEL. To recall a stored state, you must use the same memory location used previously to store the state.

***RCL {1|2|3 }**

This command recalls a previously stored state. To recall a stored state, you must use the same memory location used previously to store the state. You recall *RST states or values of the power supply from a memory location that was not previously specified as a storage location.

Calibration commands

See [Calibration overview](#) for an overview of the calibration features of the power supply. For more detailed discussion of the calibration procedures, see the Service Guide.

CALibration:COUNT?

This command queries the power supply to determine the number of times it has been calibrated. Your power supply was calibrated before it left the factory. When you receive your power supply, read the count to determine its initial value. Since the value increments by one for each calibration point, a complete calibration for three outputs will increase the value by six counts.

CALibration:CURRENT[:DATA] <numeric value>

This command can only be used after calibration is unsecured. It enters a current value of a selected output that you obtained by reading an external meter. You must first select a calibration level (CAL:CURR:LEV) for the value being entered. Two successive values (one for each end of the calibration range) must be selected and entered. The power supply then computes new calibration constants. These constants are then stored in non-volatile memory.

CALibration:CURRENT:LEVEL {MINimum|MAXimum}

Before using this command, you must select the output which is to be calibrated by using INSTRUMENT command. This command can only be used after calibration is unsecured. It sets the power supply to a calibration point that is entered with CALibration:CURRENT[:DATA] command. During calibration, two points must be entered and the low-end point (MIN) must be selected and entered first.

CALibration:SECure:CODE <new code>

This command enters a new security code. To change the security code, first unsecure the power supply using the old security code. Then, enter the new code. The calibration code may contain up to 12 characters over the remote interface but the first character must always be a letter.

CALibration:SECure:STATe {OFF|ON>}, <code>

This command unsecures or secures the power supply for calibration. The calibration code may contain up to 12 characters over the remote interface.

CALibration:SECure:STATe?

This command queries the secured state for calibration of the power supply. The returned parameter is “0” (OFF) or “1” (ON).

CALibration:STRing <quoted string>

This command records calibration information about your power supply. For example, you can store such information as the last calibration date, the next calibration due date, or the power supply’s serial number. The calibration message may contain up to 40 characters. The power supply should be unsecured before sending a calibration message.

CALibration:STRing?

This command queries the calibration message and returns a quoted string.

CALibration:VOLTage[:DATA] <numeric value>

This command can only be used after calibration is unsecured. It enters a voltage value of a selected output that you obtained by reading an external meter. You must first select a calibration level (CAL:VOLT:LEV) for the value being entered. Two successive values (one for each end of the calibration range) must be selected and entered. The power supply then computes new voltage calibration constants. These constants are then stored in non-volatile memory.

CALibration:VOLTage:LEVel {MINimum|MAXimum}

Before using this command, you must select the output which is to be calibrated by using INSTRument command. This command can only be used after calibration is unsecured. It sets the power supply to a calibration point that is entered with CALibration:VOLTage[:DATA] command. During calibration, two points must be entered and the low-end point (MIN) must be selected.

RS-232 Interface Commands

Use the front-panel “I/O configuration” key to select the baud rate, parity, and the number of data bits (See [Calibration overview](#)“, for more information).

SYSTem:LOCal

This command places the power supply in the local mode during RS-232 operation. All keys on the front panel are fully functional.

SYSTem:REMOte

This command places the power supply in the remote mode for RS-232 operation. All keys on the front panel, except the “Local” key, are disabled.

NOTE

It is very important that you send the SYSTem:REMOte command to place the power supply in the remote mode. Sending or receiving data over the RS-232 interface when not configured for remote operation can cause unpredictable results.

SYSTem:RWLock

This command places the power supply in the remote mode for RS-232 operation. This command is the same as the SYSTem:REMOte command except that all keys on the front panel are disabled, including the “Local” key.

Ctrl-C

This command clears the operation in progress over the RS-232 interface and discard any pending output data. This is equivalent to the IEEE-488 device clear action over the GPIB interface.

The SCPI status registers

All SCPI instruments implement status registers in the same way. The status system records various instrument conditions in three register groups: the Status Byte register, the Standard Event register, and the Questionable Status register group. The status byte register records high-level summary information reported in the other register groups. The diagrams on the subsequent pages illustrate the SCPI status system used by the power supply.

An example program is included in chapter 6, “Application Programs,” which shows the use of the status registers. You may find it useful to refer to the program after reading the following section in this chapter.

What is an event register?

An event register is a read-only register that reports defined conditions within the power supply. Bits in an event register are latched. Once an event bit is set, subsequent state changes are ignored. Bits in an event register are automatically cleared by a query of that register (such as *ESR? or STAT:QUES:EVENT?) or by sending the *CLS (clear status) command. A reset (*RST) or device clear will not clear bits in event registers. Querying an event register returns a decimal value which corresponds to the binary-weighted sum of all bits set in the register.

What is an enable register?

An enable register defines which bits in the corresponding event register are logically ORed together to form a single summary bit. Enable registers are both readable and writable. Querying an enable register will not clear it. The *CLS (clear status) command does not clear enable registers but it does clear the bits in the event registers. To enable bits in an enable register, you must write a decimal value which corresponds to the binary-weighted sum of the bits you wish to enable in the register.

What is a multiple logical output?

The three-logical outputs of the power supply include an INSTRument summary status register and an individual instrument ISUMmary register for each logical output. The ISUMmary registers report to the INSTRument register, which in turn reports to bit 13 of the Questionable status register. This is shown pictorially on the next page. Using such a status register configuration allows a status event to be cross-referenced by output and type of event. The INSTRument register indicates which output(s) have generated an event. The ISUMmary register is a pseudo-questionable status register for a particular logical output.

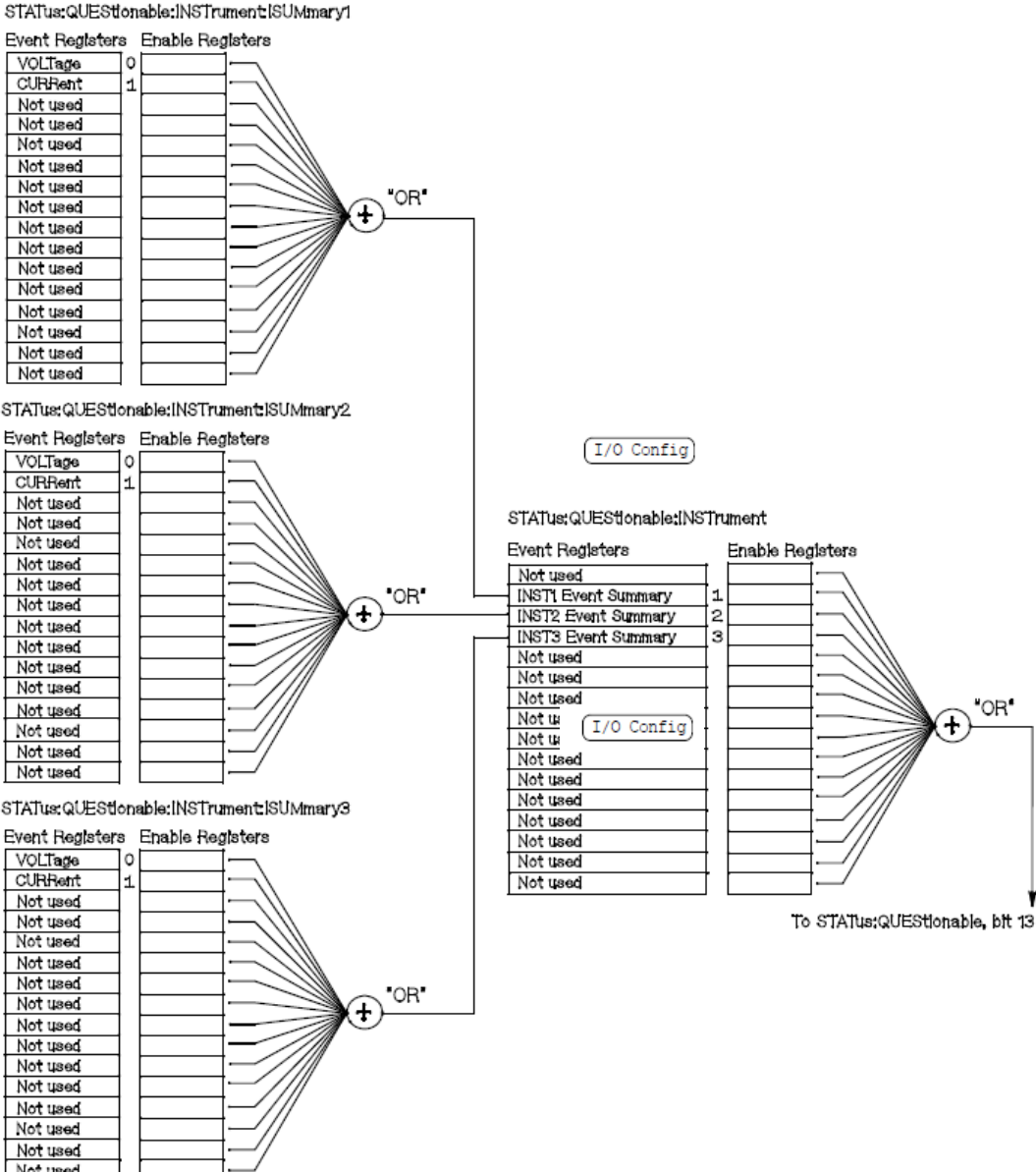

SCPI status system

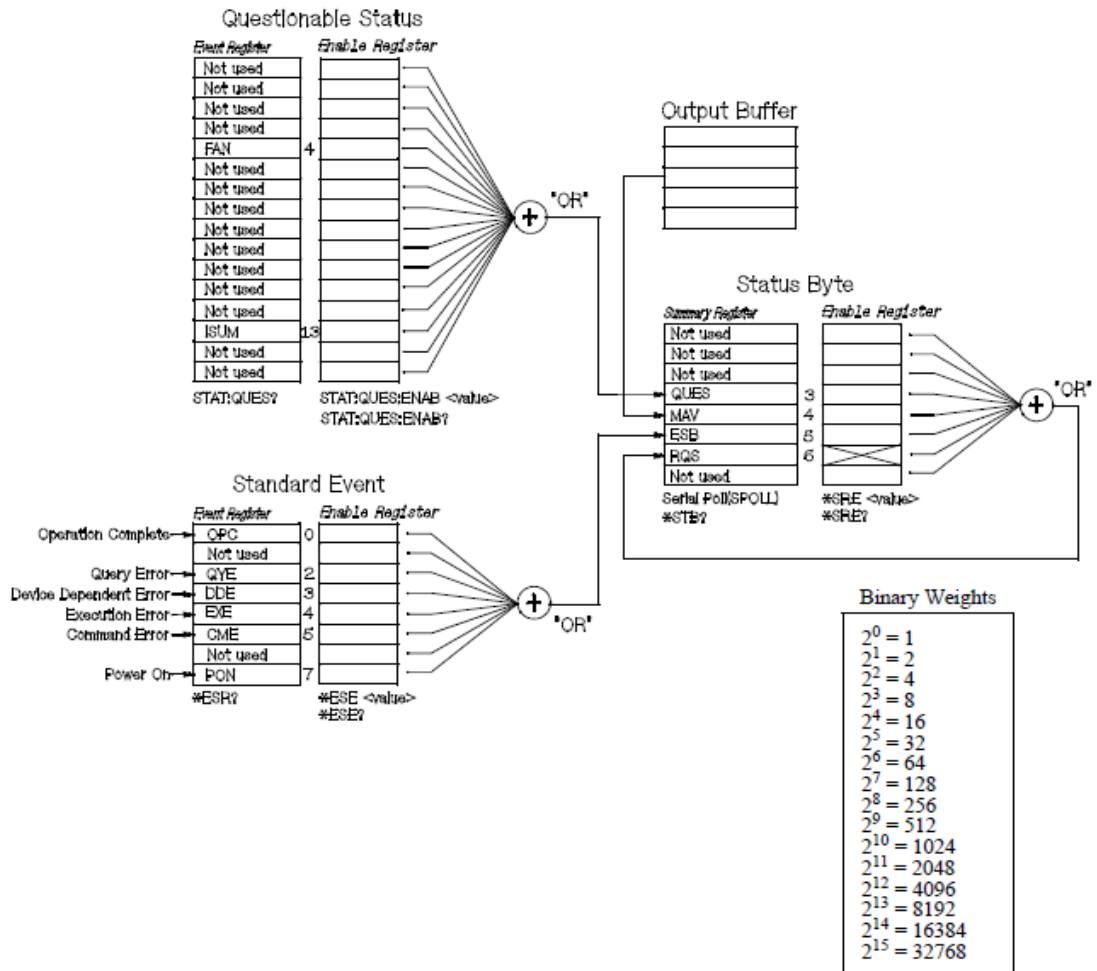

The questionable status register

The Questionable Status register provides information about unexpected operation of the power supply. Bit 4 reports a fault with the fan, and bit 13 summarizes questionable outputs for any of the three supplies. For example if one of the three supplies is in constant voltage mode and due to an overload loses regulation, bit 13 is set (latched). Send the command `STAT:QUES?` to read the register. To make use of bit 13 you must first enable registers you wish to summarize with bit 13. Send `STAT:QUES:INST:ENAB 14` to enable the Questionable Instrument register. Then send `STAT:QUES:INST:ISUM<n>:ENAB 3` for each supply to enable the Questionable Instrument Summary register, where n is 1, 2, or 3.

Table 4-2 Bit definitions - questionable status register

Bit		Decimal value	Definition
0-3	Not used	0	Always set to 0.
4	FAN	16	The fan has a fault condition.
5-12	Not Used	0	Always set to 0.
13	ISUM	8192	Summary of QUES:INST and QUES:INST:ISUM registers.
14-15	Not Used	0	Always set to 0.

The questionable instrument status register

The Questionable instrument register provides information about unexpected operations for each of the three supplies. For example if the +6V supply is in the constant voltage mode and loses regulation, then bit 1 set indicating a possible overload in the +6V supply. The +25V supply is reported as bit 2, and the -25V supply as bit 3. Send the command `STAT QUES:INST?` to read the register. The `STAT:QUES:INST:ISUM<n>` registers must be enabled to make use of the Questionable Instrument register. Send `STAT:QUES:INST:ISUM<n>:ENAB 3` to enable output n.

The questionable instrument summary register

There are three Questionable Instrument Summary registers, one for each supply output. These registers provide information about voltage and current regulation. Bit 0 is set when the voltage becomes unregulated, and bit 1 is set if the current becomes unregulated. For example if a supply which is operating as a voltage source (constant voltage mode) momentarily goes to constant current mode, bit 0 is set to indicate that the voltage output is not regulated. To read the register for each supply, send `STAT:QUES:INST:ISUM<n>?`, where n is 1, 2, or 3.

To determine the operating mode (CV or CC) for the power supply send `STAT:QUES:INST:ISUM<n>:COND?`, where n is 1, 2, or 3 depending on the output. Bit 1 true indicates the output is in constant voltage mode, bit 0 true indicates constant current mode, both bits true indicates neither the voltage nor the current is regulated, and both bits false indicates the outputs of the power supply are off.

The Questionable Status Event register is cleared when:

- You execute the `*CLS` (clear status) command.
- You query the event register using `STATus:QUESTionable[:EVENT]?` (Status Questionable Event register) command.

For example, 16 is returned when you have queried the status of the questionable event register, the FAN condition is questionable.

The Questionable Status Enable register is cleared when:

- You execute `STATus:QUESTionable:ENABle 0` command.

For example, you must send the `STAT:QUES:ENAB 16` to enable the FAN bit.

The standard event register

The Standard Event register reports the following types of instrument events: poweron detected, command syntax errors, command execution errors, self-test or calibration errors, query errors, or when an *OPC command is executed. Any or all of these conditions can be reported in the Standard Event Summary bit (ESB, bit 5) of Status Byte register through the enable register. To set the enable register mask, you write a decimal value to the register using the *ESE (Event Status Enable) command.

An error condition (Standard Event register bits 2, 3, 4, or 5) will always record one or more errors in the power supply's error queue. Read the error queue using the SYSTem:ERRor? command.

Table 4-3 Bit definitions - standard event register

Bit		Decimal value	Definition
0	OPC	1	Operation Complete. All commands prior to and including an *OPC command have been executed
1	Not Used	0	Always set to 0.
2	QYE	4	Query Error. The power supply tried to read the output buffer but it was empty. Or, new command line was received before a previous query had been read. Or, both the input and output buffers are full.
3	DDE	8	Device Error. A self-test or calibration error occurred (see error numbers 601 through 748 in chapter 5).
4	EXE	16	Execution Error. An execution error occurred (see error numbers -211 through -224 in chapter 5).
5	CME	32	Command Error. A command syntax error occurred (see error number -101 through -178 in chapter 5).
6	Not Used	0	Always set to 0.
7	PON	128	Power On. Power has been turned off and on since the last time the event register was read or cleared.

The Standard Event register is cleared when:

- You execute the *CLS (clear status) command.
- You query the event register using the *ESR? (Event Status register) command.

For example, 28 (4 + 8 + 16) is returned when you have queried the status of the Standard Event register, QYE, DDE, and EXE conditions have occurred.

The Standard Event Enable register is cleared when:

- You execute the *ESE 0 command.
- You turn on the power and have previously configured the power supply using the *PSC 1 command.
- The enable register will not be cleared at power-on if you have previously configured the power supply using the *PSC 0 command. For example, you must send the *ESE 24 (8 + 16) to enable DDE and EXE bits.

The status byte register

The Status Byte summary register reports conditions from the other status registers. Query data that is waiting in the power supply's output buffer is immediately reported through the "Message Available" bit (bit 4) of Status Byte register. Bits in the summary register are not latched. Clearing an event register will clear the corresponding bits in the Status Byte summary register. Reading all messages in the output buffer, including any pending queries, will clear the message available bit.

Table 4-4 Bit definitions - status byte summary register

Bit		Decimal value	Definition
0-2	Not Used	0	Always set to 0.
3	QUES	8	One or more bits are set in the questionable status register (bits must be "enabled" in the enable register).
4	MAV	16	Data is available in the power supply output buffer.

5	ESB	32	One or more bits are set in the standard event register (bits must be “enabled” in the enable register).
6	RQS	64	The power supply is requesting service (serial poll).
7	Not Used	0	Always set to 0.

The Status Byte Summary register is cleared when:

- You execute the *CLS (clear status) command.
- Querying the Standard Event register (*ESR? command) will clear only bit 5 in the Status Byte summary register.

For example, 24 (8 + 16) is returned when you have queried the status of the Status Byte register, QUES and MAV conditions have occurred.

The Status Byte Enable register (Request Service) is cleared when:

- You execute the *SRE 0 command.
- You turn on the power and have previously configured the power supply using the *PSC 1 command.
- The enable register will not be cleared at power-on if you have previously configured the power supply using *PSC 0.

For example, you must send the *SRE 96 (32 + 64) to enable ESB and RQS bits.

Using Service Request (SRQ) and Serial POLL

You must configure your bus controller to respond to the IEEE-488 service request (SRQ) interrupt to use this capability. Use the Status Byte enable register (*SRE command) to select which summary bits will set the low-level IEEE-488 service request signal. When bit 6 (request service) is set in the Status Byte, an IEEE-488 service request interrupt message is automatically sent to the bus controller. The bus controller may then poll the instruments on the bus to identify which one requested service (the instrument with bit 6 set in its Status Byte).

The request service bit is cleared only by reading the Status Byte using an IEEE-488 serial poll or by reading the event register whose summary bit is causing the service request.

To read the Status Byte summary register, send the IEEE-488 serial poll message. Querying the summary register will return a decimal value which corresponds to the binary-weighted sum of the bits set in the register. Serial poll will automatically clear the “request service” bit in the Status Byte summary register. No other bits are affected. Performing a serial poll will not affect instrument throughput.

CAUTION

The IEEE-488 standard does not ensure synchronization between your bus controller program and the instrument. Use the *OPC? command to guarantee that commands previously sent to the instrument have completed. Executing a serial poll before a *RST,*CLS, or other commands have completed can cause previous conditions to be reported.

Using *STB? to read the status byte

The *STB? (Status Byte query) command is similar to a serial poll but it is processed like any other instrument command. The *STB? command returns the same result as a serial poll but the “request service” bit (bit 6) is not cleared.

The *STB? command is not handled automatically by the IEEE-488 bus interface hardware and will be executed only after previous commands have completed. Polling is not possible using the *STB? command. Executing the *STB? command does not clear the Status Byte summary register.

Using the message available bit (MAV)

You can use the Status Byte “message available” bit (bit 4) to determine when data is available to read into your bus controller. The power supply subsequently clears bit 4 only after all messages have been read from the output buffer.

To interrupt your bus controller using SRQ

- 1 Send a device clear message to clear the power supply's output buffer (e.g., CLEAR 705).
- 2 Clear the event registers with the *CLS (clear status) command.

- 3 Set up the enable register masks. Execute the *ESE command to set up the Standard Event register and the *SRE command for the Status Byte.
- 4 Send the *OPC? (operation complete query) command and enter the result to ensure synchronization.
- 5 Enable your bus controller's IEEE-488 SRQ interrupt.

To determine when a command sequence is completed

- 1 Send a device clear message to clear the power supply's output buffer (e.g., CLEAR 705).
- 2 Clear the event registers with the *CLS (clear status) command.
- 3 Enable the “operation complete” bit (bit 0) in the Standard Event register by executing the *ESE 1 command.
- 4 Send the *OPC? (operation complete query) command and enter the result to ensure synchronization.
- 5 Execute your command string to program the desired configuration, and then execute the *OPC (operation complete) command as the last command. When the command sequence is completed, the “operation complete” bit (bit 0) is set in the Standard Event register.
- 6 Use a serial poll to check to see when bit 5 (standard event) is set in the Status Byte summary register. You could also configure the power supply for an SRQ interrupt by sending *SRE 32 (Status Byte enable register, bit 5).

Using *OPC to signal when data is in the output buffer

Generally, it is best to use the “operation complete” bit (bit 0) in the Standard Event register to signal when a command sequence is completed. This bit is set in the register after an *OPC command has been executed. If you send *OPC after a command which loads a message in the power supply's output buffer (query data), you can use the “operation complete” bit to determine when the message is available. However, if too many messages are generated before the *OPC command executes (sequentially), the output buffer will fill and the power supply will stop processing commands.

Status reporting commands

See diagram [The SCPI status registers](#) in this chapter for detailed information of the status register structure of the power supply.

SYSTem:ERRor?

This query command reads one error from the error queue. When the front-panel ERROR annunciator turns on, one or more command syntax or hardware errors have been detected. A record of up to 20 errors can be stored in the power supply's error queue. See [Error Messages](#) in chapter 5.

- Errors are retrieved in first-in-first-out (FIFO) order. The first error returned is the first error that was stored. When you have read all errors from the queue, the ERROR annunciator turns off. The power supply beeps once each time an error is generated.
- If more than 20 errors have occurred, the last error stored in the queue (the most recent error) is replaced with -350, "Queue overflow". No additional errors are stored until you remove errors from the queue. If no errors have occurred when you read the error queue, the power supply responds with +0, "No error".
- The error queue is cleared when power has been off or after a *CLS (clear status) command has been executed. The *RST (reset) command does not clear the error queue.

STATus:QUEStionable[:EVENT]?

This command queries the Questionable Status event register. The power supply returns a decimal value which corresponds to the binary-weighted sum of all bits in the register.

STATus:QUEStionable:ENABle <enable value>

This command enables bits in the Questionable Status enable register. The selected bits are then reported to the Status Byte.

STATus:QUEStionable:ENABle?

This command queries the Questionable Status enable register. The power supply returns a binary-weighted decimal representing the bits set in the enable register.

STATus:QUEStionable:INSTrument[:EVENT]?

This command queries the Questionable Instrument event register. The power supply returns a decimal value which corresponds to the binary-weighted sum of all bits in the register and clears the register.

STATus:QUEStionable:INSTrument:ENABle <enable value>

This command sets the value of the Questionable Instrument enable register. This register is a mask for enabling specific bits from the Questionable Instrument event register to set the Instrument Summary bit (ISUM, bit 13) of the Questionable Status register. The “ISUM” bit of the Questionable Status register is the logical OR of all the Questionable Instrument event register bits that are enabled by the Questionable Instrument enable register.

STATus:QUEStionable:INSTrument:ENABle?

This query returns the value of the Questionable Instrument enable register.

STATus:QUEStionable:INSTrument:ISUMmary<n>[:EVENT]?

This query returns the value of the Questionable Instrument Isummary event register for a specific output of the three-output power supply. The particular output must be specified by a numeric value. n is 1, 2, or 3. See Table 4-1 on page 74 for the output number. The event register is a read-only register which holds (latches) all events. Reading the Questionable Instrument Isummary event register clears it.

STATus:QUEStionable:INSTrument:ISUMmary<n>:CONDition?

This query returns the CV or CC condition of the specified instrument. If “2” is returned, the queried instrument is in the CV operating mode. If “1” is returned, the queried instrument is in the CC operating mode. If “0” is returned, the outputs

of the instrument are off or unregulated. If '3' is returned, the instrument is in the hardware failure. n is 1, 2, or 3.

STATus:QUESTionable:INSTrument:ISUMmary<n>:ENABle <enable value>

This command sets the value of the Questionable Instrument Isummary enable register for a specific output of the three-output power supply. The particular output must be specified by a numeric value. n is 1, 2, or 3. See Table 4-1 on page 74 for the output number. This register is a mask for enabling specific bits from the Questionable Instrument Isummary event register to set the Instrument Summary bit (bit 1, 2, and 3) of the Questionable Instrument register. These bits 1, 2, and bit 3 are the logical OR of all the Questionable Instrument Isummary event register bits that are enabled by the Questionable Instrument Isummary enable register.

STATus:QUESTionable:INSTrument:ISUMmary<n>:ENABle?

This query returns the value of the Questionable Instrument Isummary enable register. n is 1, 2, or 3.

*CLS

This command clears all event registers and Status Byte register.

*ESE<enable value>

This command enables bits in the Standard Event enable register. The selected bits are then reported to the Status Byte.

*ESE?

This command queries the Standard Event enable register. The power supply returns a decimal value which corresponds to the binary-weighted sum of all bits in the register.

***ESR?**

This command queries the Standard event register. The power supply returns a decimal value which corresponds to the binary-weighted sum of all bits in the register.

***OPC**

This command sets the “Operation Complete” bit (bit 0) of the Standard Event register after the command is executed.

***OPC?**

This command returns “1” to the output buffer after the command is executed.

***PSC { 0|1 }**

(Power-on status clear.) This command clears the Status Byte and the Standard Event register enable masks when power is turned on (*PSC 1). When *PSC 0 is in effect, the Status Byte and Standard Event register enable masks are not cleared when power is turned on.

***PSC?**

This command queries the power-on status clear setting. The returned parameter is “0” (*PSC 0) or “1” (*PSC 1).

***SRE <enable value>**

This command enables bits in the Status Byte enable register.

***SRE?**

This command queries the Status Byte Enable register. The power supply returns a decimal value which corresponds to the binary-weighted sum of all bits set in the register.

*STB?

This command queries the Status Byte summary register. The *STB? command is similar to a serial poll but it is processed like any other instrument command. The *STB? command returns the same result as a serial poll but the “Request Service” bit (bit 6) is not cleared if a serial poll has occurred.

*WAI

This command instructs the power supply to wait for all pending operations to complete before executing any additional commands over the interface. Used only in the triggered mode.

An introduction to the SCPI language

SCPI (Standard Commands for Programmable Instruments) is an ASCII-based instrument command language designed for test and measurement instruments. Refer to “Simplified Programming Overview”, starting on page 70 for an introduction to the basic techniques used to program the power supply over the remote interface.

SCPI commands are based on a hierarchical structure, also known as a tree system. In this system, associated commands are grouped together under a common node or root, thus forming subsystems. A portion of the SOURce subsystem is shown below to illustrate the tree system.

[SOURce:]

```
CURRent {<current>|MIN|MAX}
```

```
CURRent? [MIN|MAX]
```

```
CURRent:
```

```
    TRIGgered {<current>|MIN|MAX}
```

```
    TRIGgered?{MIN|MAX}
```

```
VOLTage {<voltage>|MIN|MAX}
```

```
VOLTage? [MIN|MAX]
```

```
VOLTage:
```

```
    TRIGgered {<voltage>|MIN|MAX}
```

```
    TRIGgered? {MIN|MAX}
```

SOURce is the root keyword of the command, CURRent and VOLTage are second-level keywords, and TRIGgered is third-level keywords. A colon (:) separates a command keyword from a lower-level keyword.

Command format used in this manual

The format used to show commands in this manual is shown below:

```
CURRent {<current>|MINimum|MAXimum}
```

The command syntax shows most commands (and some parameters) as a mixture of upper- and lower-case letters. The upper-case letters indicate the abbreviated spelling for the command. For shorter program lines, send the abbreviated form. For better program readability, send the long form.

For example, in the above syntax statement, CURR and CURRENT are both acceptable forms. You can use upper- or lower-case letters. Therefore, CURRENT, curr, and Curr are all acceptable. Other forms, such as CUR and CURREN, will generate an error.

Braces ({ }) enclose the parameter choices for a given command string. The braces are not sent with the command string.

A vertical bar (|) separates multiple parameter choices for a given command string.

Triangle brackets (< >) indicate that you must specify a value for the enclosed parameter. For example, the above syntax statement shows the current parameter enclosed in triangle brackets. The brackets are not sent with the command string. You must specify a value for the parameter (such as "CURR 0.1").

Some parameters are enclosed in square brackets ([]). The brackets indicate that the parameter is optional and can be omitted. The brackets are not sent with the command string. If you do not specify a value for an optional parameter, the power supply chooses a default value.

A colon (:) separates a command keyword from a lower-level keyword. You must insert a blank space to separate a parameter from a command keyword. If a command requires more than one parameter, you must separate adjacent parameters using a comma as shown below:

```
"SOURce:CURRent:TRIGgered"
```

```
"APPL P6V,3.5,1.5"
```

Command separators

A colon (:) is used to separate a command keyword from a lower-level keyword as shown below:

```
"SOURce:CURRent:TRIGgered"
```

A semicolon (;) is used to separate two commands within the same subsystem, and can also minimize typing. For example, sending the following command string:

```
"SOUR:VOLT MIN;CURR MAX"
```

... is the same as sending the following two commands:

```
"SOUR:VOLT MIN"
```

```
"SOUR:CURR MAX"
```

Use a colon and a semicolon to link commands from different subsystems. For example, in the following command string, an error is generated if you do not use the colon and semicolon:

```
"INST P6V;;SOUR:CURR MIN"
```

Using the MIN and MAX parameters

You can substitute MINimum or MAXimum in place of a parameter for many commands. For example, consider the following command:

```
CURRent {<current>|MIN|MAX}
```

Instead of selecting a specific current, you can substitute MINimum to set the current to its minimum value or MAXimum to set the current to its maximum value.

Querying parameter settings

You can query the value of most parameters by adding a question mark (?) to the command. For example, the following command sets the output current to 5 amps:

```
"CURR 5"
```

You can query the value by executing:

```
"CURR?"
```

You can also query the minimum or maximum value allowed with the present function as follows:

```
"CURR? MAX"
```

```
"CURR? MIN"
```

CAUTION

If you send two query commands without reading the response from the first, and then attempt to read the second response, you may receive some data from the first response followed by the complete second response. To avoid this, do not send a query command without reading the response. When you cannot avoid this situation, send a device clear before sending the second query command.

SCPI Command Terminators

A command string sent to the power supply must terminate with a <new line> character. The IEEE-488 EOI (end-or-identify) message is interpreted as a <new line> character and can be used to terminate a command string in place of a <new line> character. A <carriage return> followed by a <new line> is also accepted. Command string termination will always reset the current SCPI command path to the root level.

IEEE-488.2 Common Commands

The IEEE-488.2 standard defines a set of common commands that perform functions like reset, self-test, and status operations. Common commands always begin with an asterisk (*), are four to five characters in length, and may include one or more parameters. The command keyword is separated from the first parameter by a blank space. Use a semicolon (;) to separate multiple commands as shown below:

```
"*RST; *CLS; *ESE 32; *OPC?"
```

SCPI Parameter Types

The SCPI language defines several different data formats to be used in program messages and response messages.

Numeric Parameters Commands that require numeric parameters will accept all commonly used decimal representations of numbers including optional signs, decimal points, and scientific notation. Special values for numeric parameters like MINimum, MAXimum, and DEFault are also accepted. You can also send engineering unit suffixes (V, A or SEC) with numeric parameters. If only specific numeric values are accepted, the power supply will automatically round the input numeric parameters. The following command uses a numeric parameter:

```
CURR {<current>|MINimum|MAXimum}
```

Discrete Parameters Discrete parameters are used to program settings that have a limited number of values (like BUS, IMM). Query responses will always return the short form in all upper-case letters. The following command uses discrete parameters:

```
TRIG:SOUR {BUS|IMM}
```

Boolean Parameters Boolean parameters represent a single binary condition that is either true or false. For a false condition, the power supply will accept "OFF" or "0". For a true condition, the power supply will accept "ON" or "1". When you query a boolean setting, the power supply will always return "0" or "1". The following command uses a boolean parameter:

```
DISP {OFF|ON}
```

String Parameters String parameters can contain virtually any set of ASCII characters. A string must begin and end with matching quotes; either with a single quote or with a double quote. You can include the quote delimiter as part of the string by typing it twice without any characters in between. The following command uses a string parameter:

```
DISPlay:TEXT <quoted string>
```

Halting an Output in Progress

You can send a device clear at any time to stop an output in progress over the GPIB interface. The status registers, the error queue, and all configuration states are left unchanged when a device clear message is received. Device clear performs the following actions.

- The power supply's input and output buffers are cleared.
- The power supply is prepared to accept a new command string.
- The following statement shows how to send a device clear over the GPIB interface using Keysight BASIC.

```
CLEAR 705 : IEEE-488 Device Clear
```

- The following statement shows how to send a device clear over the GPIB interface using the GPIB Command Library for C or QuickBASIC.

```
IOCLEAR (705)
```

For RS-232 operation, sending the <Ctrl-C> character will perform the same operation as the IEEE-488 device clear message. The power supply's DTR (data terminal ready) handshake line is set true following a device clear message. See DTR/DSR Handshake Protocol, in Chapter 3 for further details.

NOTE

All remote interface configurations can be entered only from the front panel. See **RS-232 Interface Commands** in Chapter 3 to configure for GPIB or RS-232 interface before operating the power supply remotely.

SCPI Conformance Information

The Keysight E3631A Power Supply conforms to the 1995.0 version of the SCPI standard. Many of the commands required by the standard are accepted by the power supply but are not described in this manual for simplicity or clarity. Most of these non-documented commands duplicate the functionality of a command already described in this manual.

SCPI Confirmed Commands

The following table lists the SCPI-confirmed commands that are used by the power supply.

SCPI Confirmed Commands

DISPlay

```
[[:WINDow]][:STATe] {OFF|ON}
[:WINDow]][:STATe]?
[:WINDow]:TEXT[:DATA] <quoted string>
[:WINDow]:TEXT[:DATA]?
[:WINDow]:TEXT:CLEAr
```

INSTrument

```
[[:SElect] {P6V|P25V|N25V}
[:SElect]?
:NSElect :{1|2|3}
:NSElect?
COUPlE[:TRIGger] {ALL|NONE} <list>
COUPlE[:TRIGger]?
```

MEASure

```
:CURRent[:DC]?
```

[:VOLTage][:DC]?

OUTPUT

[:STATe] {OFF/ON}

[:STATE]?

[SOURce]

:CURRent[:LEVel][:IMMediate][:AMPLitude] {<current>|MIN|MAX}

:CURRent[:LEVel][:IMMediate][:AMPLitude]? [MIN|MAX]

:CURRent[:LEVel]:TRIGgered[AMPLitude] {<current>|MIN|MAX}

:CURRent[:LEVel]:TRIGgered[:AMPLitude]? [MIN|MAX]

:VOLTage[:LEVel][:IMMediate][:AMPLitude] {<voltage>|MIN|MAX}

:VOLTage[:LEVel][IMMediate][:AMPLitude]?[MIN:MAX]

:VOLTage[:LEVel]:TRIGgered[:AMPLitude] {<voltage>|MIN|MAX}

:VOLTage[:LEVel]:TRIGgered[:AMPLitude]?[MIN|MAX]

STATus

:QUEStionable[:EVENT]?

:QUEStionable:ENABle <enable value>

:QUEStionable:ENABle?

:QUEStionable:INSTrument[:EVENT]?

:QUEStionable:INSTrument:ENABle <enable value>

:QUEStionable:INSTrument:ENABle?

:QUEStionable:INSTrument:ISUMary<n>[:EVENT]?

:QUEStionable:INSTrument:ISUMary<n>:CONDition?

:QUEStionable:INSTrument:ISUMary<n>:ENABle <enable value>

:QUEStionable:INSTrument:ISUMary<n>:ENABle?

SYSTem

:BEEPer[:IMMEDIATE]

:ERRor?

:VERSion

TRIGger

[:SEQuence]:DELay {<seconds>|MIN|MAX}

[:SEQuence]:DELay?

[:SEQuence]:SOURce{BUS|IMM}

[:SEQuence]:SOURce?

INITiate[:IMMEDIATE]

Device Specific Commands

The following commands are device-specific to the Keysight E3631A power supply. They are not included in the 1995.0 version of the SCPI standard. However, these commands are designed with the SCPI standard in mind and they follow all of the command syntax rules defined by the standard.

Non-SCPI Commands

APPLY

```
{P6V|P25V|N25V}[,{<voltage>|DEF|MIN|MAX}>}[,{<current>|DEF|MIN|MAX}]
APPLY? [{P6V|P25V|N25}]
```

CALibration

```
:COUNT?
:CURRENT[:DATA] <numeric value>
:CURRENT:LEVEL {MIN|MAX}
:SECure:CODE <new code>
:SECure:STATE {OFF|ON},<code>
:SECure:STATE?
:STRING <quoted string>
:STRING?
:VOLTage[:DATA] <numeric value>
:VOLTage:LEVEL {MIN|MAX}
```

MEASure

```
:CURRENT[:DC]? [{P6V|P25V|N25V}]
[:VOLTage][:DC]? [{P6V|P25V|N25V}]
```

OUTPUT

```
:TRACK[:STATE] {OFF|ON}
:TRACK[:STATE]?
```

SYSTem
:LOCal
:REMote
:RWLock

IEEE-488 Conformance information

Dedicated hardware lines		IEEE-488 common commands
ATN	Attention	
IFC	Interface Clear	*CLS
REN	Remote Enable	*ESE <enable value>
SRQ	Service Request Enable	*ESE?
Addressed commands		*ESR?
DCL	Device Clear	*IDN?
EOI	End or Identify	*OPC
GET	Group Execute Trigger	*OPC?
GTL	Go To Local	*PSC {0 1}
LLO	Local Lockout	*PSC?
SDC	Selected Device Clear	*RST
SPD	Serial Poll Disable	*SAV {1 2 3}
		*RCL {1 2 3}
		*SRE <enable value>
		*SRE?
		*STB?
		*TRG
SPE	Serial Poll Enable	*TST?
		*WAI

5 Error Messages

- Execution Errors 139
- Self-Test Errors 144
- Calibration Errors 145

Error Messages

When the front-panel ERROR annunciator turns on, one or more command syntax or hardware errors have been detected. A record of up to 20 errors is stored in the power supply's error queue. The power supply beeps once each time an error is generated.

- Errors are retrieved in first-in-first-out (FIFO) order. The first error returned is the first error that was stored. When you have read all errors from the queue, the ERROR annunciator turns off.
- If more than 20 errors have occurred, the last error stored in the queue (the most recent error) is replaced with -350, "Queue overflow". No additional errors are stored until you remove errors from the queue. If no errors have occurred when you read the error queue, the supply responds with + 0, "No error" over the remote interface or "NO ERRORS" from the front panel.
- The error queue is cleared when power has been off or after a *CLS (clear status) command has been executed. The *RST (reset) command does not clear the error queue.
- Front-panel operation:
 - If the ERROR annunciator is on, press the "Error" key repeatedly to read the errors stored in the queue. The error queue is cleared when you read all errors.



- Remote interface operation:
 - SYSTem:ERRor? : Reads one error from the error queue
- Errors have the following format (the error string may contain up to 80 characters).
- 113,"Undefined header"

Execution Errors

-101	<p>Invalid character</p> <p>An invalid character was found in the command string. You may have inserted a character such as #, \$, or % in the command keyword or within a parameter.</p> <p>Example: OUTP:TRAC #ON</p>
-102	<p>Syntax error</p> <p>Invalid syntax was found in the command string. You may have inserted a blank space before or after a colon in the command header, or before a comma.</p> <p>Example: VOLT:LEV ,1</p>
-103	<p>Invalid separator</p> <p>An invalid separator was found in the command string. You may have used a comma instead of a colon, semicolon, or blank space - or you may have used a blank space instead of a comma.</p> <p>Example: TRIG:SOUR,BUS or APPL P6V 1.0 1.0</p>
-104	<p>Data type error</p> <p>The wrong parameter type was found in the command string. You may have specified a number where a string was expected, or vice versa.</p>
-105	<p>GET not allowed</p> <p>A Group Execute Trigger (GET) is not allowed within a command string.</p>
-108	<p>Parameter not allowed</p> <p>More parameters were received than expected for the command. You may have entered an extra parameter, or you added a parameter to a command that does not accept a parameter.</p> <p>Example: OUTP? 10</p>
-109	<p>Missing parameter</p> <p>Fewer parameters were received than expected for the command. You omitted one or more parameters that are required for this command.</p> <p>Example: APPL</p>
-112	<p>Program mnemonic too long</p> <p>A command header was received which contained more than the maximum 12 characters allowed.</p>
-113	<p>Undefined header</p> <p>A command was received that is not valid for this power supply. You may have misspelled the command or it may not be a valid command. If you are using the short form of the command, remember that it may contain up to four letters.</p> <p>Example: TRIGG:DEL 3</p>

Error Messages

-114 ^[1]	Header suffix out of range The numeric suffix attached to a command header is not one of the allowable values. Example: STAT:QUES:INST:ISUM4?
-120 ^[1]	Numeric data error An invalid number was specified for a numeric parameter. Example: VOLT 1.0E+320000
-121	Invalid character in number An invalid character was found in the number specified for a parameter value. Example: *ESE #B01010102
-123	Numeric overflow A numeric parameter was found whose exponent was larger than 32,000.
-124	Too many digits A numeric parameter was found whose mantissa contained more than 255 digits, excluding leading zeros.
-128	Numeric data not allowed A numeric parameter was received but a character string was expected. Example: DISP:TEXT 123
-130 ^[1]	Suffix error A suffix was incorrectly specified for a numeric parameter. You may have misspelled the suffix or the numeric parameter does not accept a suffix. Example: TRIG:DEL 0.5 SECS
-131	Invalid suffix A suffix was incorrectly specified for a numeric parameter. You may have misspelled the suffix. Example: TRIG:DEL 0.5 SECS
-134	Suffix too long A suffix for a numeric parameter contained too many characters.
-138	Suffix not allowed A suffix was received following a numeric parameter which does not accept a suffix. Example: STAT:QUES:ENAB 18 SEC (SEC is not a valid suffix).
-141	Invalid character data Either the character data element contained an invalid character or the particular element received was not valid for the header.

-144	Character data too long The character data element contained too many characters.
-148	Character data not allowed A discrete parameter was received but a character string or a numeric parameter was expected. Check the list of parameters to verify that you have used a valid parameter type. Example: DISP:TEXT ON
-151	Invalid string data An invalid character string was received. Check to see if you have enclosed the character string in single or double quotes. Example: DISP:TEXT 'ON'
-158	String data not allowed A character string was received but is not allowed for the command. Check the list of parameters to verify that you have used a valid parameter type. Example: TRIG:DEL 'zero'
-160 to -168	Block data errors The power supply does not accept block data.
-170 to -178	Expression errors The power supply does not accept mathematical expressions.
-211	Trigger ignored A Group Execute Trigger (GET) or *TRG was received but the trigger was ignored. Make sure that the trigger source should be selected to the bus and the trigger subsystem should be initiated by INIT[:IMM] command.
-213 ^[1]	Trigger ignored An INITiate command was received but could not be executed because a measurement was already in progress. Send a device clear to halt a measurement in progress and place the power supply in the "idle" state.
-221	Init ignored Indicates that a legal program data element was parsed but could not be executed due to the current device state.
-222	Data out of range A numeric parameter value is outside the valid range for the command. Example: TRIG:DEL -3
-223	Too much data A character string was received but could not be executed because the string length was more than 40 characters. This error can be generated by the CALibration:STRing command.

Error Messages

-224	Illegal parameter value <p>A discrete parameter was received which was not a valid choice for the command. You may have used an invalid parameter choice. Example: DISP:STAT XYZ (XYZ is not a valid choice).</p>
-330	Self-test failed <p>The power supply's complete self-test failed from the remote interface (*TST? command). In addition to this error, more specific self-test errors are also reported. See also "Self-Test Errors", starting on See "Self-Test Errors", for more information in chapter 5.</p>
-350	Queue overflow <p>The error queue is full because more than 20 errors have occurred. No additional errors are stored until you remove errors from the queue. The error queue is cleared when power has been off, or after a *CLS (clear status) command has been executed.</p>
-410	Query INTERRUPTED <p>A command was received which sends data to the output buffer, but the output buffer contained data from a previous command (the previous data is not overwritten). The output buffer is cleared when power has been off, or after a *RST (reset) command has been executed.</p>
-420	Query UNTERMINATED <p>The power supply was addressed to talk (i.e., to send data over the interface) but a command has not been received which sends data to the output buffer. For example, you may have executed an APPLY command (which does not generate data) and then attempted an ENTER statement to read data from the remote interface.</p>
-430	Query DEADLOCKED <p>A command was received which generates too much data to fit in the output buffer and the input buffer is also full. Command execution continues but all data is lost.</p>
-440	Query UNTERMINATED after indefinite response <p>The *IDN? command must be the last query command within a command string. Example: *IDN?;:SYST:VERS?</p>
501	Isolator UART framing error
502	Isolator UART overrun error
503 ^[1]	SPI data error <p>Data error was detected during the communication between the main controller U10 and the I/O controller U21.</p>
511	RS-232 framing error
512	RS-232 overrun error

513	RS-232 parity error
	Command allowed only with RS-232
514	There are three commands which are only allowed with the RS-232 interface: SYSTem:LOCal, SYSTem:REMOte, and SYSTem:RWLock.
521	Input buffer overflow
522	Output buffer overflow
	Command not allowed in local
550	You should always execute the SYSTem:REMOte command before sending other commands over the RS-232 interface.
800	P25V and N25V coupled by track system The OUTP:TRAC should be off when coupling between the +25V output and the -25V output.
801	P25V and N25V coupled by trigger subsystem The +25V output and the -25V output should be uncoupled to enable the tracking operation for those outputs

[1] This error message is only applicable for serial MY53xx6xxx.

Self-Test Errors

The following errors indicate failures that may occur during a self-test. Refer to the Service Guide for more information.

601	Front panel does not respond
602	RAM read/write failed
603	A/D sync stuck
604	A/D slope convergence failed
605	Cannot calibrate rundown gain
606	Rundown gain out of range
607	Rundown too noisy
608	Serial configuration readback failed
609 ^[1]	System ADC test failed
624	Unable to sense line frequency
625	I/O processor does not respond
626	I/O processor failed self-test
630	Fan test failed
631	System DAC test failed
632	P6V hardware test failed
633	P25V hardware test failed
634	N25V hardware test failed

^[1]This error message is only applicable for serial MY53xx6xxx.

Calibration Errors

The following errors indicate failures that may occur during a calibration. Refer to the Service Guide for more information.

701	<p>Cal security disabled by jumper</p> <p>The calibration security feature has been disabled with a jumper inside the power supply. When applicable, this error will occur at power-on to warn you that the power supply is unsecured.</p>
702	<p>Cal secured</p> <p>The power supply is secured against calibration.</p>
703	<p>Invalid secure code</p> <p>An invalid calibration security code was received when attempting to unsecure or secure the power supply. You must use the same security code to unsecure the power supply as was used to secure it, and vice versa. The security code may contain up to 12 alphanumeric characters. The first character must be a letter.</p>
704	<p>Secure code too long</p> <p>A security code was received which contained more than 12 characters.</p>
708	<p>Cal output disabled</p> <p>Calibration is aborted by sending OUP OFF command during calibrating an output.</p>
711	<p>Cal sequence interrupted</p> <p>Calibration sequence is interrupted by changing the instrument selection during calibrating an output.</p>
712	<p>Bad DAC cal data</p> <p>The specified DAC calibration constants (CAL:VOLT or CAL:CURR) are out of range. Note that the new calibration constants are not stored in the non-volatile memory.</p>
713	<p>Bad read back cal data</p> <p>The specified readback calibration constants (CAL:VOLT or CAL:CURR) are out of range. Note that the new calibration constants are not stored in the non-volatile memory.</p>
740	Cal checksum failed, secure state
741	Cal checksum failed, string data
742	Cal checksum failed, store/recall data in location 1

Error Messages

743	Cal checksum failed, store/recall data in location 2
744	Cal checksum failed, store/recall data in location 3
745	Cal checksum failed, DAC cal constants
746	Cal checksum failed, readback cal constants
747	Cal checksum failed, GPIB address
748	Cal checksum failed, internal data

THIS PAGE HAS BEEN INTENTIONALLY LEFT BLANK.

6 Application Programs

This chapter contains several remote interface application programs to help you develop programs for your own application. Chapter 4, [Remote Interface Reference](#), lists the syntax for the SCPI (Standard Commands for Programmable Instruments) commands available to program the power supply.

- Keysight BASIC Programs [148](#)
- C and QuickBASIC language programs [148](#)
- Using the APPLY command [149](#)
- Using the Low-Level Commands [158](#)
- Using the Status Registers [163](#)
- RS-232 Operation Using QuickBASIC [166](#)

Keysight BASIC Programs

All of the Keysight BASIC example programs in this chapter were developed and tested on an HP 9000 Series 300 controller. Each device on the GPIB (IEEE-488) interface must have a unique address. You can set the power supply's address to any value between 0 and 30. The current address is displayed momentarily on the front panel when you turn on the power supply.

The GPIB (IEEE-488) address is set to "05" when the power supply is shipped from the factory. The example programs in this chapter assume an GPIB address of 05. When sending a command over the remote interface, you append this address to the GPIB interface's select code (normally "7"). For example, if the select code is "7" and the device address is "05", the combination is "705".

C and QuickBASIC language programs

All of the C and QuickBASIC Language example programs in this chapter are written for the Keysight 82335 GPIB Interface Card using the GPIB Command Library for C. Unless otherwise noted, the library functions used in the example programs are compatible with the ANSI C standard. All of the C Language programs were compiled and tested using the following compilers:

- Microsoft® QuickC® Version 2.0
- Borland® Turbo C® ++ Version 1.0

To compile the program to make an executable file, refer to the language manuals. To link the object file you must previously specify TCLHPIB.LIB as a required library file from the menu.

Using the APPLy command

This program demonstrates the following concepts:

- How to use the APPLy command to set output voltages and currents for three outputs.
- How to use the *SAV command to store the instrument configuration in memory.

Keysight BASIC / GPIB (Program 1)

10 !

20 ! This program sets the output voltages and currents for

30 ! three outputs. This program also shows how to use "state

40 ! storage" to store the instrument configuration in memory.

50 !

60 ASSIGN @Psup TO 705 ! Assign I/O path to address 705

70 CLEAR 7 ! Clear interface - send "device clear"

80 OUTPUT @Psup;"*RST;*CLS" ! Reset and clear the power supply

90 OUTPUT @Psup;"*OPC" ! Verify reset command has executed

100 !

110 OUTPUT @Psup;"APPL P6V, 5.0, 1.0" ! Set 5.0 volts/1.0 amp to +6V output

120 OUTPUT @Psup;"APPL P25V, 15.0, 1.0" ! Set 15.0 volts/1.0 amp to +25V
output

130 OUTPUT @Psup;"APPL N25V, -10.0, 0.8"! Set -10.0 volts/0.8 amps to -25V
output

140 !

150 OUTPUT @Psup;"OUTP ON" ! Enable the outputs

160 !

170 OUTPUT @Psup;"*SAV 1" ! Store a state in memory location 1"

180 !

190 ! Use the "*RCL 1" command to recall the stored state

```
200 !
210 END
```

C / GPIB (Program 1)

```

/*****
This program sets up output voltages and currents for three outputs.
This program also shows how to use "state storage" to store the instrument
configuration in memory.
*****/

#include <stdio.h> /* Used for printf() */
#include <stdlib.h> /* Used for atoi() */
#include <string.h> /* Used for strlen() */
#include <cfunc.h> /* Header file from GPIB Command Library */
#define ADDR 705L /* Set GPIB address for power supply */
/* Function Prototypes */
void rst_clear(void);
void out_setting(void);
void output_on(void);
void command_exe(char *commands[], int length);
void state_save(void);
void check_error(char *func_name);
/*****

void main(void) /* Start of main() */
{
rst_clear(); /* Reset the instrument and clear error queue */
output_on(); /* Enable the outputs
out_setting(); /* Set output voltages currents */

```

```

state_save(); /* Save a state of the power supply */
}
/*****/
void rst_clear(void)
{
/* Reset the power supply, clear the error queue, and wait for
commands to complete. A "1" is sent to the output buffer from the
*OPC? command when *RST and *CLS are completed. */
IOOUTPUTS(ADDR, "*RST;*CLS;*OPC", 14);
}
/*****/
void out_setting(void)
{
/* Set 5.0 volts/1.0 amp to +6V output, 15 volts/1.0 amp to +25V output
and -10 volts/0.8 amps to -25V output. */
static char *cmd_string[]=
{
"APPL P6V, 5.0, 1.0;" /* Set 5.0 volts / 1.0 amp to +6V output */
"APPL P25V, 15.0, 1.0;" /* Set 15.0 volts / 1.0 amp to +25V output */
"APPL N25V, -10.0, 0.8" /* Set -10.0 volts / 0.8 amp to -25V output */
};
/* Call the function to execute the command strings shown above */
command_exe(cmd_string, sizeof(cmd_string)/sizeof(char*));
/* Call the function to check for errors */
check_error("out_setting");
}
/*****/
void output_on(void)

```

```

{
IOOUTPUTS(ADDR, "OUTP ON", 7) /*Enable the outputs
}
/*****/
void command_exe(char *commands[], int length)
{
/* Execute one command string at a time using a loop */
int loop;
for (loop = 0; loop < length; loop++)
{
IOOUTPUTS(ADDR, commands[loop], strlen(commands[loop]));
}
}
/*****/
void check_error(char *func_name)
{
/* Read error queue to determine if errors have occurred */
char message[80];
int length = 80;
IOOUTPUTS(ADDR, "SYST:ERR?", 9); /* Read the error queue */
IOENTERS(ADDR, message, &length); /* Enter error string */
while (atoi(message) != 0) /* Loop until all errors are read */
{
printf("Error %s in function %s\n\n", message, func_name);
IOOUTPUTS(ADDR, "SYST:ERR?", 9);
IOENTERS(ADDR, message, &length);
}
}
}

```



```
/******  
void state_save(void)  
{  
/* Store a instrument state in memory location 1. */  
IOOUTPUTS(ADDR, "*SAV 1", 6); /* Save the state in memory location 1*/  
}  
/******
```

End of Program 1

C / GPIB (Program 1)

```

/*****
This program sets up output voltages and currents for three outputs.
This program also shows how to use "state storage" to store the instrument
configuration in memory.
*****/

#include <stdio.h> /* Used for printf() */
#include <stdlib.h> /* Used for atoi() */
#include <string.h> /* Used for strlen() */
#include <cfunc.h> /* Header file from GPIB Command Library */
#define ADDR 705L /* Set GPIB address for power supply */
/* Function Prototypes */
void rst_clear(void);
void out_setting(void);
void output_on(void);
void command_exe(char *commands[], int length);
void state_save(void);
void check_error(char *func_name);
/*****
void main(void) /* Start of main() */
{
rst_clear(); /* Reset the instrument and clear error queue */
output_on(); /* Enable the outputs
out_setting(); /* Set output voltages currents */
state_save(); /* Save a state of the power supply */
}
*****/

```

```

void rst_clear(void)
{
/* Reset the power supply, clear the error queue, and wait for
commands to complete. A "1" is sent to the output buffer from the
*OPC? command when *RST and *CLS are completed. */
IOOUTPUTS(ADDR, "*RST;*CLS;*OPC", 14);
}
/*****/

void out_setting(void)
{
/* Set 5.0 volts/1.0 amp to +6V output, 15 volts/1.0 amp to +25V output
and -10 volts/0.8 amps to -25V output. */
static char *cmd_string[]=
{
"APPL P6V, 5.0, 1.0;" /* Set 5.0 volts / 1.0 amp to +6V output */
"APPL P25V, 15.0, 1.0;" /* Set 15.0 volts / 1.0 amp to +25V output */
"APPL N25V, -10.0, 0.8" /* Set -10.0 volts / 0.8 amp to -25V output */
};
/* Call the function to execute the command strings shown above */
command_exe(cmd_string, sizeof(cmd_string)/sizeof(char*));
/* Call the function to check for errors */
check_error("out_setting");
}
/*****/

void output_on(void)
{
IOOUTPUTS(ADDR, "OUTP ON", 7) /*Enable the outputs
}

```

```

/*****/
void command_exe(char *commands[], int length)
{
/* Execute one command string at a time using a loop */
int loop;
for (loop = 0; loop < length; loop++)
{
IOOUTPUTS(ADDR, commands[loop], strlen(commands[loop]));
}
}
/*****/
void check_error(char *func_name)
{
/* Read error queue to determine if errors have occurred */
char message[80];
int length = 80;
IOOUTPUTS(ADDR, "SYST:ERR?", 9); /* Read the error queue */
IOENTERS(ADDR, message, &length); /* Enter error string */
while (atoi(message) != 0) /* Loop until all errors are read */
{
printf("Error %s in function %s\n\n", message, func_name);
IOOUTPUTS(ADDR, "SYST:ERR?", 9);
IOENTERS(ADDR, message, &length);
}
}
/*****/
void state_save(void)
{

```

```
/* Store a instrument state in memory location 1. */  
IOOUTPUTS(ADDR, "*SAV 1", 6); /* Save the state in memory location 1*/  
}  
/*****/  
End of Program 1
```

Using the Low-Level Commands

This program demonstrates the following concepts:

- How to use the low-level commands to program three outputs.
- How to specify a trigger source and trigger the power supply over the GPIB interface.

Keysight BASIC / GPIB (Program 2)

```
10 !
20 ! This program uses low-level SCPI commands to program the
30 ! power supply to output a 3 volts/0.5 amps for +6V output,
40 ! 20 volts/0.9 amps for +25V output, and 10 volts/0.5 amps for
50 ! -25V output. This program also shows the use of a trigger
60 ! received over the GPIB interface to initiate a single trigger.
70 !
80 ASSIGN @Psup TO 705 ! Assign I/O path to address 705
80 CLEAR 7 ! Clear the GPIB interface
90 OUTPUT @Psup;"*RST" ! Reset the power supply
100 !
110 OUTPUT @Psup;"INST:COUP:TRIG ALL" ! Couple three outputs
120 OUTPUT @Psup;"TRIG:SOUR BUS" ! Trigger source is "bus"
130 OUTPUT @Psup;"TRIG:DEL 30" ! Time delay 30 seconds"
140 !
150 OUTPUT @Psup;"INST:SEL P6V" ! Select +6V output
160 OUTPUT @Psup;"VOLT:TRIG 3" ! Set the pending voltage to 3 volts
170 OUTPUT @Psup;"CURR:TRIG 0.5" ! Set the pending current to 0.5 amps
180 !
190 OUTPUT @Psup;"INST:SEL P25V" ! Select +25V output
```

```

200 OUTPUT @Psup;"VOLT:TRIG 20" ! Set the pending voltage to 20 volts
210 OUTPUT @Psup;"CURR:TRIG 0.9" ! Set the pending current to 0.9 amps
220 !
230 OUTPUT @Psup;"INST:SEL N25V" ! Select -25V output
240 OUTPUT @Psup;"VOLT:TRIG -10" ! Set the pending voltage to -10 volts
250 OUTPUT @Psup;"CURR:TRIG 0.5" ! Set the pending current to 0.5 amps
260 !
270 OUTPUT @Psup;"OUTP ON" ! Enable the outputs
280 !
290 OUTPUT @Psup;"INIT" ! Initiate the trigger subsystem
300
310 ! Trigger the power supply over the GPIB interface
320 !
330 OUTPUT @Psup;"*TRG" ! Set output changes after time delay
340 !
350 OUTPUT @Psup;"INST:COUP:TRIG NONE" ! Uncouple three outputs!
360 !
370 END

```

QuickBASIC / GPIB (Program 2)

```

REM $INCLUDE: 'QBSETUP'
'
' This program uses low-level SCPI commands to program the power
' supply to output 3 volts/0.5 amps for +6V output, 20 volts/0.9 amps
' for +25V output, and 10 volts/0.5 amps for -25V output. This program
' also shows the use of a trigger received over the GPIB interface to
' initiate a single trigger. The program is written in QuickBASIC and
' uses Keysight 82335 GPIB card and GPIB command library.

```

```
'  
ISC& = 7 ' GPIB select code is "7"  
Dev& = 705 ' Assign I/O path to address 705  
Timeout = 5 ' Configure device library for a 5 second timeout  
CALL IOTIMEOUT(ISC&, Timeout)  
IF PCIB.ERR <> NOERR THEN ERROR PCIB.BASERR  
CALL IORESET(ISC&) ' Reset the Keysight 82335 GPIB card  
IF PCIB.ERR <> NOERR THEN ERROR PCIB.BASERR  
CALL IOCLEAR(Dev&) ' Send a device clear to the power supply  
IF PCIB.ERR <> NOERR THEN ERROR PCIB.BASERR  
CALL IOREMOTE(Dev&) ' Place the power supply in the remote mode  
IF PCIB.ERR <> NOERR THEN ERROR PCIB.BASERR  
Info1$ = "*RST" ' Reset the power supply  
Length1% = LEN(Info1$)  
CALL IOOUTPUTS(Dev&, Info1$, Length1%)  
IF PCIB.ERR <> NOERR THEN ERROR PCIB.BASERR  
Info1$ = "INST:COUP:TRIG ALL" ' Couple three outputs  
Length1% = LEN(Info1$)  
CALL IOOUTPUTS(Dev&, Info1$, Length1%)  
IF PCIB.ERR <> NOERR THEN ERROR PCIB.BASERR  
Info1$ = "TRIG:SOUR BUS" ' Trigger source is "bus"  
Length1% = LEN(Info1$)  
CALL IOOUTPUTS(Dev&, Info1$, Length1%)  
IF PCIB.ERR <> NOERR THEN ERROR PCIB.BASERR  
Info1$ = "TRIG:DEL 30" ' Set 30 seconds of time time delay  
Length1% = LEN(Info1$)  
CALL IOOUTPUTS(Dev&, Info1$, Length1%)  
IF PCIB.ERR <> NOERR THEN ERROR PCIB.BASERR
```



```

Info1$ = "INST:SEL P6V" ' Select +6V output?
Length1% = LEN(Info1$)
CALL IOOUTPUTS(Dev&, Info1$, Length1%)
IF PCIB.ERR <> NOERR THEN ERROR PCIB.BASERR
Info1$ = "VOLT:TRIG 3" ' Set the pending voltage to 3 volts
Length1% = LEN(Info1$)
CALL IOOUTPUTS(Dev&, Info1$, Length1%)
IF PCIB.ERR <> NOERR THEN ERROR PCIB.BASERR
Info1$ = "CURR:TRIG 0.5" ' Set the pending current to 0.5 amps
Length1% = LEN(Info1$)
CALL IOOUTPUTS(Dev&, Info1$, Length1%)
IF PCIB.ERR <> NOERR THEN ERROR PCIB.BASERR
Info1$ = "INST:SEL P25V" ' Select +25V output
Length1% = LEN(Info1$)
CALL IOOUTPUTS(Dev&, Info1$, Length1%)
IF PCIB.ERR <> NOERR THEN ERROR PCIB.BASERR
Info1$ = "VOLT:TRIG 20" ' Set the pending voltage to 20 volts
Length1% = LEN(Info1$)
CALL IOOUTPUTS(Dev&, Info1$, Length1%)
IF PCIB.ERR <> NOERR THEN ERROR PCIB.BASERR
Info1$ = "CURR:TRIG 0.9" ' Set the pending current to 0.9 amps
Length1% = LEN(Info1$)
CALL IOOUTPUTS(Dev&, Info1$, Length1%)
IF PCIB.ERR <> NOERR THEN ERROR PCIB.BASERR
Info1$ = "INST:SEL N25V" ' Select -25V output
Length1% = LEN(Info1$)
CALL IOOUTPUTS(Dev&, Info1$, Length1%)
IF PCIB.ERR <> NOERR THEN ERROR PCIB.BASERR

```

Application Programs

```
Info1$ = "VOLT:TRIG -10" ' Set the pending voltage to -10 volts
Length1% = LEN(Info1$)
CALL IOOUTPUTS(Dev&, Info1$, Length1%)
IF PCIB.ERR <> NOERR THEN ERROR PCIB.BASERR
Info1$ = "CURR:TRIG 0.5" ' Set the pending current to 0.5 amps
Length1% = LEN(Info1$)
CALL IOOUTPUTS(Dev&, Info1$, Length1%)
IF PCIB.ERR <> NOERR THEN ERROR PCIB.BASERR
Info1$ = "OUTP ON" ' Enable the outputs
Length1% = LEN(Info1$)
CALL IOOUTPUTS(Dev&, Info1$, Length1%)
IF PCIB.ERR <> NOERR THEN ERROR PCIB.BASERR
Info1$ = "INIT" ' Initiate the trigger subsystem
Length1% = LEN(Info1$)
CALL IOOUTPUTS(Dev&, Info1$, Length1%)
IF PCIB.ERR <> NOERR THEN ERROR PCIB.BASERR
Info1$ = "*TRG" ' Set output changes after time delay
Length1% = LEN(Info1$)
CALL IOOUTPUTS(Dev&, Info1$, Length1%)
IF PCIB.ERR <> NOERR THEN ERROR PCIB.BASERR
Info1$ = "INST:COUP:TRIG NONE" ' Uncouple three outputs
Length1% = LEN(Info1$)
CALL IOOUTPUTS(Dev&, Info1$, Length1%)
IF PCIB.ERR <> NOERR THEN ERROR PCIB.BASERR
END
```

End of Program 2

Using the Status Registers

This program teaches the following concepts:

- How to use the Status Registers to generate an interrupt if a SCPI error occurs. The program sets up the Status Byte and Standard Event register and interrupts the controller if an error is detected.
- How to service the interrupt if an error occurs and read the power supply's error queue using the SYST:ERR? command.

Keysight BASIC / GPIB (Program 3)

```

10 !
20 ! This program uses the status registers to generate an
30 ! interrupt if a SCPI error occurs. The power supply
40 ! is programmed to output a 3V/0.5A for +6V output,
50 ! 10V/0.8A for +25V output, and -15V/0.2A for -25V output.
60 !
70 ASSIGN @Psup TO 705 ! Assign I/O path to address 705
80 COM @Psup ! Use same address in subprogram
90 INTEGER Gpib,Mask,Value,B ! Declare integer variables
100 CLEAR 7 ! Clear interface
110 OUTPUT @Psup;"*RST" ! Reset power supply
120 !
130 ! Set up error checking
140 !
150 Gpib=7 ! GPIB select code is "7"
160 ON INTR Gpib CALL Err_msg ! Call subprogram if error occurs
170 Mask=2 ! Bit 1 is SRQ
180 ENABLE INTR Gpib;Mask ! Enable SRQ to interrupt program

```

Application Programs

```
190 !
200 OUTPUT @Psup;"*SRE 32" ! Enable "Standard Event" bit in Status Byte
210 ! to pull the IEEE-488 SRQ line
220 OUTPUT @Psup;"*ESE 60" ! Enable error bits (2, 3, 4, or 5) to set
230 ! "Standard Event" bit in Status Byte
240 ! and wait for operation complete
250 OUTPUT @Psup;"*CLS" ! Clear status registers
260 !
270 ! Set the power supply to an output for three outputs
280 !
290 OUTPUT @Psup;"APPL P6V,3.0, 0.5" ! Set 3 V/0.5 A for +6V output,
300 OUTPUT @Psup;"APPL P25V,10.0, 0.8" ! Set 10 V/0.8 A for +25V output,
310 OUTPUT @Psup;"APPL N25V,-15.0, 0.2"! Set -15 V/0.2 A for -25V output
320 !
330 OUTPUT @Psup;"OUTP ON"! ! Enable the outputs
340 !
350 OUTPUT @Psup;"*OPC" ! Verify previous commands has executed
360 !
370 OFF INTR Gpib ! Disable interrupts
380 END
390 !
400 !*****
410 !
420 SUB Err_msg ! Error subprogram is called if errors occurred
430 DIM Message$(80) ! Dimension array for error
440 INTEGER Code ! Define integer variable
450 COM @Psup ! Use same address as in main program
460 B=SPOLL(@Psup) ! Use Serial Poll to read Status Byte
```

```
470 ! (all bits are cleared too)
480 !
490 ! Loop until error queue is cleared
500 !
510 REPEAT
520 OUTPUT @Psup;"SYST:ERR?"
530 ENTER @Psup;Code,Message$
540 PRINT Code,Message$
550 UNTIL Code=0
560 STOP
570 SUBEND
```

End of Program 3

RS-232 Operation Using QuickBASIC

The following example shows how to send command instruction and receive command responses over the RS-232 interface using QuickBASIC.

RS-232 Operation Using QuickBASIC (Program 4)

```
CLS
LOCATE 1, 1
DIM cmd$(100), resp$(100)
' Set up serial port for 9600 baud, none parity, 8 bits;
' Ignore Request to Send and Carrier Detect; Send line feed,
' enable parity check, reserve 1000 bytes for input buffer
OPEN "com1:9600,n,8,2,rs,cd,lf,pe" FOR RANDOM AS #1 LEN = 1000
'
' Put the power supply into the remote operation mode
PRINT #1, "SYST:REM"
'
'Reset and clear the power supply
PRINT #1, "*RST;*CLS"
'
' Query the power supply's id string
PRINT #1, "*IDN?"
LINE INPUT #1, resp$
PRINT "*IDN? returned: ", resp$
'
' Ask what revision of SCPI the power supply conforms to
PRINT #1, "SYST:VERS?"
LINE INPUT #1, resp$
```

```
PRINT "SYST:VERS? returned: ", resp$
'|
'| Generate a beep
PRINT #1, "SYST:BEEP"
'|
'| Set the +6V outputs to 3 V, 3 A
PRINT #1, "APPL P6V, 3.0, 3.0"
'|
'| Enable the outputs
PRINT #1, "OUTP ON"
'|
'| Query the output voltage for +6V output
PRINT #1, "MEAS:VOLT? P6V"
LINE INPUT #1, resp $
PRINT "MEAS:VOLT? P6V returned: ", resp$
END
```

End of Program 4

THIS PAGE HAS BEEN INTENTIONALLY LEFT BLANK.

7 Tutorial

The Keysight E3631A is a high performance instrument capable of delivering clean DC power. But to take full advantage of the performance characteristics designed into the power supply, certain basic precautions must be observed when connecting it for use on the lab bench or as a controlled power supply. This chapter describes basic operation of linear power supplies and gives specific details on the operation and use of the Keysight E3631A DC power supply:

- Overview of Keysight E3631A Operation 170
- Output Characteristics 172
- Connecting the Load 177
- Extending the Voltage 180
- Remote Programming 181
- Reliability 183

Overview of Keysight E3631A Operation

Series regulated power supplies were introduced many years ago and are still used extensively today. The basic design technique, which has not changed over the years, consists of placing a control element in series with the rectifier and load device. **Figure 7-1** shows a simplified schematic of a series regulated supply with the series element depicted as a variable resistor. Feedback control circuits continuously monitor the output and adjust the series resistance to maintain a constant output voltage. Because the variable resistance of **Figure 7-1** is actually one or more power transistor operating in the linear (class A) mode, supplies with this type of regulator are often called linear power supplies. Linear power supplies have many advantages and usually provide the simplest most effective means of satisfying high performance and low power requirements.

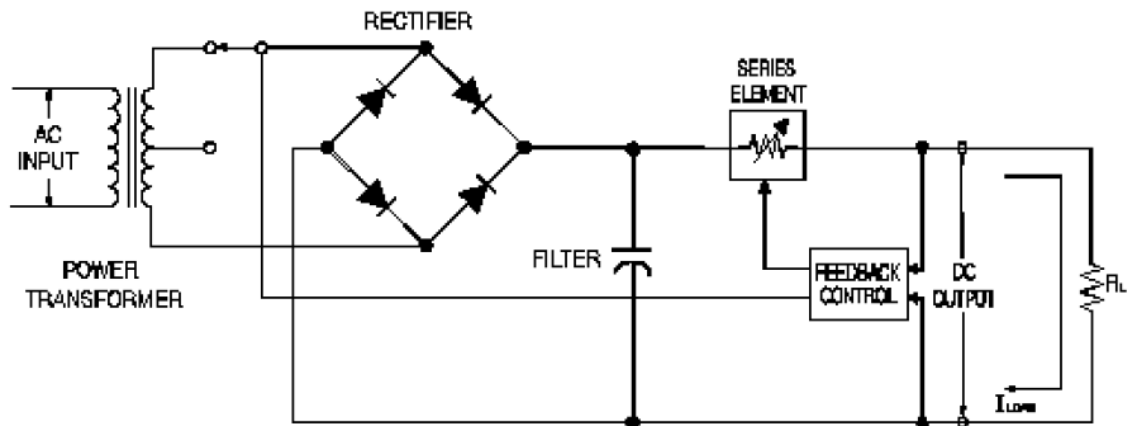

Figure 7-1 Diagram of simple series power supply with tap selection

To keep the voltage across the series resistance low, some supplies use pre-regulation before the rectifier bridge. **Figure 7-1** shows a controlled transformer tap as used in the Keysight E3631A. This is one of several techniques using semiconductors for pre-regulation to reduce the power dissipated across the series element.

In terms of performance, linear regulated supplies have a very precise regulating properties and respond quickly to variations of the line and load. Hence, their line and load regulation and transient recovery time are superior to supplies using other regulation techniques. These supplies also exhibit low ripple and noise, are tolerant of ambient temperature changes, and with their circuit simplicity, have a high reliability.

The Keysight E3631A contains three linear regulated power supplies. Each is controlled by a control circuit that provides voltages to program the outputs. Each supply sends back to the control circuit voltages representing outputs at the terminals. The control circuits receive information from the front panel and send information to the display. Similarly the control circuits “talk” to the remote interface for input and output with the GPIB and RS-232 interfaces.

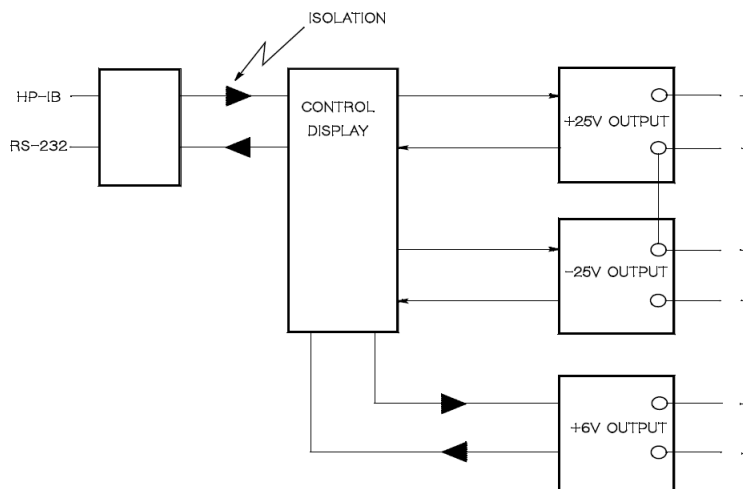

Figure 7-2 Block diagram of the three supplies showing the isolation

The control circuit and display circuit share the same common ground as the $\pm 25\text{V}$ supplies. The remote interface is at earth ground and isolated from the control circuit and the $\pm 25\text{V}$ supplies. The $+6\text{V}$ supply is also isolated from the remote interface and the $\pm 25\text{V}$ supplies.

Output Characteristics

An ideal constant-voltage power supply would have a zero output impedance at all frequencies. Thus, as shown in [Figure 7-3](#), the voltage would remain perfectly constant in spite of any changes in output current demanded by the load.

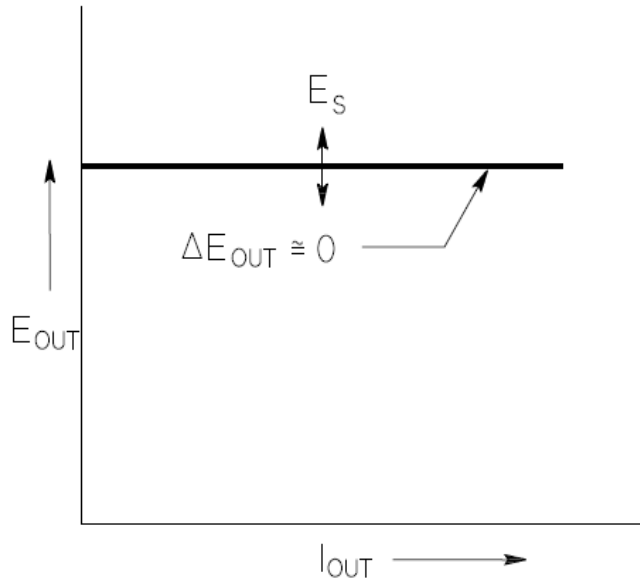

Figure 7-3 Ideal constant voltage power supply

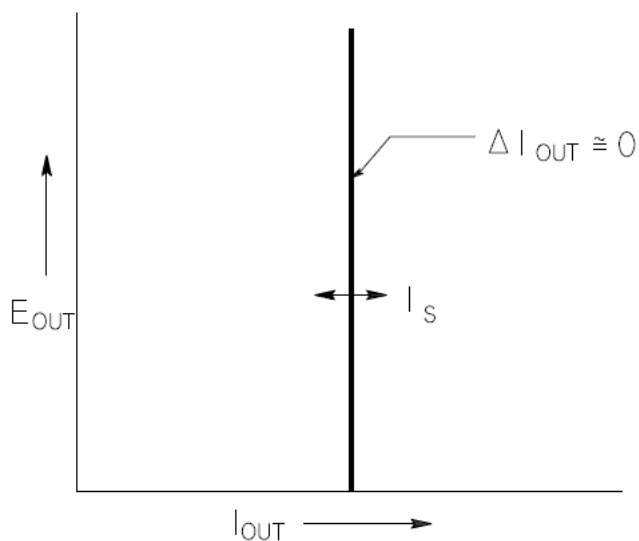

Figure 7-4 Ideal constant current power supply

The ideal constant-current power supply exhibits an infinite output impedance at all frequencies. Thus as [Figure 7-4](#) indicates, the ideal constant-current power supply would accommodate a load resistance change by altering its output voltage by just the amount necessary to maintain its output current at a constant value.

Each of the three Keysight E3631A power supply outputs can operate in either constant-voltage (CV) mode or constant-current (CC) mode. Under certain fault conditions, the power supply cannot operate in either CV or CC mode and becomes unregulated.

[Figure 7-5](#) shows the operating modes of the three outputs of the Keysight E3631A power supply. The operating point of one supply will be either above or below the line $R_L = R_C$. This line represents a load where the output voltage and the output current are equal to the voltage and current setting. When the load R_L is greater than R_C , the output voltage will dominate since the current will be less than the current setting. The power supply is said to be in constant-voltage mode. The load at point 1 has a relatively high resistance value (compared to R_C), the output voltage is at the voltage setting, and the output current is less than the

current setting. In this case the power supply is in the constant-voltage mode and the current setting acts as a current limit.

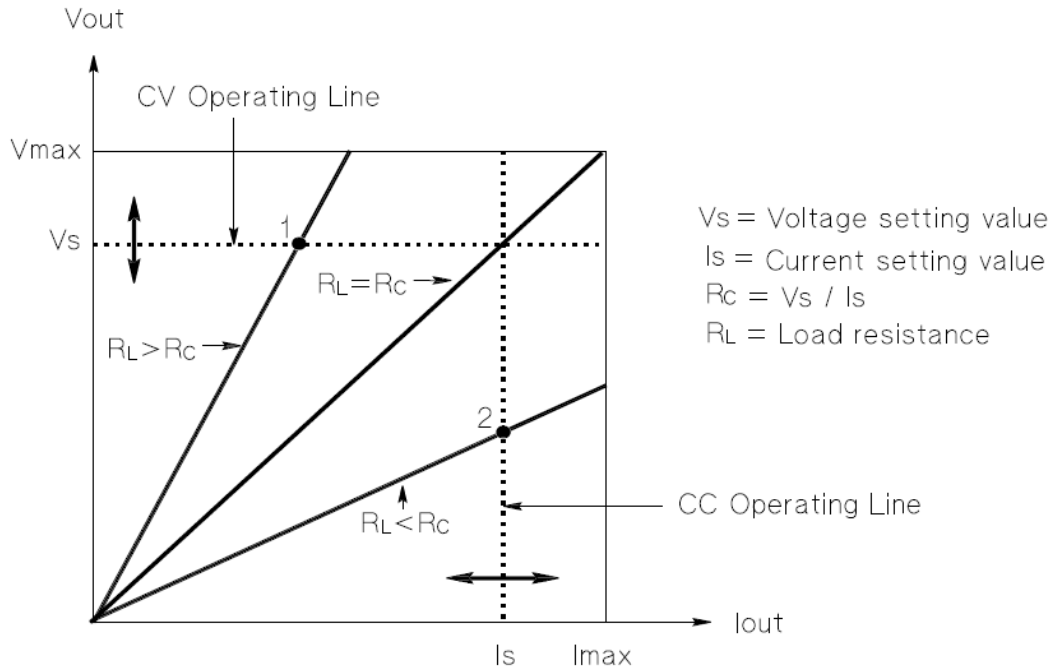

Figure 7-5 Output characteristics

When the load R_L is less than R_C , the output current will dominate since the voltage will be less than the set voltage. The power supply is said to be in constant-current mode. The load at point 2 has a relatively low resistance, the output voltage is less than the voltage setting, the output current is at the current setting. The supply is in constant-current mode and the voltage setting acts as a voltage limit.

Unregulated state

If the power supply should go into a mode of operation that is neither CV or CC, the power supply is unregulated. In this mode the output is not predictable. The unregulated condition may be the result of the ac line voltage below the specifications. The unregulated condition may occur momentarily. For example when the output is programmed for a large voltage step; the output capacitor or a large capacitive load will charge up at the current limit setting. During the ramp up of the output voltage the power supply will be in the unregulated mode. During the transition from CV to CC as when the output is shorted, the unregulated state may occur briefly during the transition.

Unwanted signals

An ideal power supply has a perfect DC output with no signals across the terminals or from the terminals to earth ground. The actual power supply has finite noise across the output terminals, and a finite current will flow through any impedance connected from either terminal to earth ground. The first is called normal mode voltage noise and the second common mode current noise.

Normal mode voltage noise is in the form of ripple related to the line frequency plus some random noise. Both of these are of very low value in the Keysight E3631A. Careful lead layout and keeping the power supply circuitry away from power devices and other noise sources will keep these values low.

Common mode noise can be a problem for very sensitive circuitry that is referenced to earth ground. When a circuit is referenced to earth ground, a low level line--related ac current will flow from the output terminals to earth ground. Any impedance to earth ground will create a voltage drop equal to the current flow multiplied by the impedance. To minimize this effect, the output terminal can be grounded at the output terminal. Alternately, any impedances to earth ground should have a complementary impedance to earth ground to cancel any generated voltages. If the circuit is not referenced to earth ground, common mode power line noise is typically not a problem.

The output will also change due to changes in the load. As the load increases the output current will cause a small drop in the output voltage of the power supply due to the output impedance R . Any resistance in the connecting wire will add to this resistance and increase the voltage drop. Using the largest possible hook up wire will minimize the voltage drop.

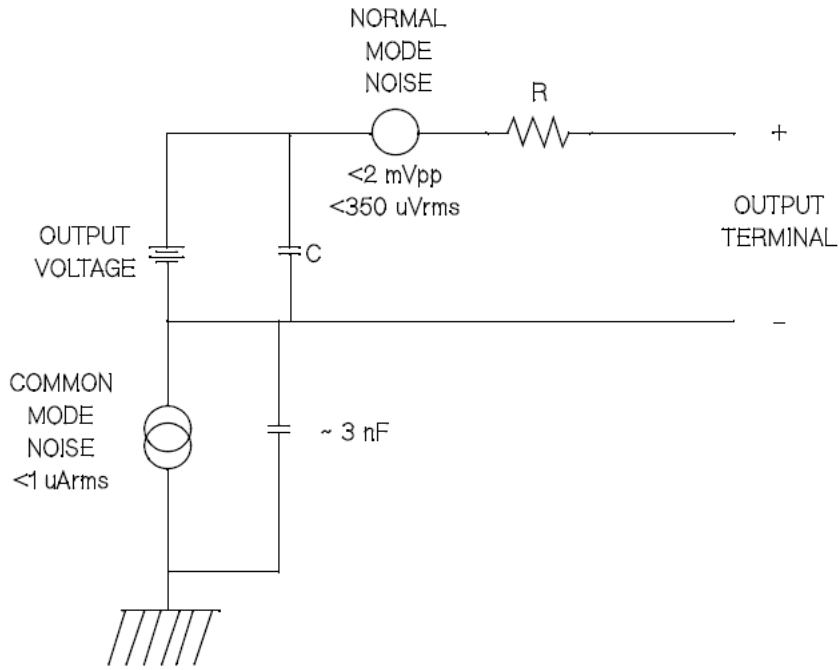

Figure 7-6 Simplified diagram of common mode and normal mode sources of noise

When the load changes very rapidly, as when a relay contact is closed, the inductance in the hook up wire and in the power supply output will cause a spike to appear at the load. The spike is a function of the rate of change of the load current. When very rapid changes in load are expected, a capacitor with a low series resistance, in parallel with the power supply, and close to the load is the best way to minimize these voltage spikes.

Connecting the Load

Connecting the load

The outputs of all three power supplies are isolated from earth ground. Any output terminal may be grounded, or an external voltage source may be connected between any terminal output and ground. However, output terminals must be kept within ± 240 VDC of ground. The ± 25 V supplies are tied together at one common terminal. Any one of the three terminals can be tied to ground as needed. An earth ground terminal is provided on the front panel for convenience.

Multiple loads

When connecting multiple loads to the power supply, each load should be connected to the output terminals using separate connecting wires. This minimizes mutual coupling effects between loads and takes full advantage of the low output impedance of the power supply. Each pair of wires should be as short as possible and twisted or shielded to reduce lead inductance and noise pick-up. If a shield is used, connect one end to the power supply ground terminal and leave the other end disconnected.

If cabling considerations require the use of distribution terminals that are located remotely from the power supply, connect output terminals to the distribution terminals by a pair of twisted or shielded wires. Connect each load to the distribution terminals separately.

Table 7-1 Wire Rating

AWG	10	12	14	16	18	20	22	24	26	28
Suggested maximum Current (amps)*	40	25	20	13	10	7	5	3.5	2.5	1.7
mΩ/ft	1.00	1.59	2.53	4.02	6.39	10.2	16.1	25.7	40.8	64.9
mΩ/m	3.3	5.2	8.3	13.2	21.0	33.5	52.8	84.3	133.9	212.9

*Single conductor in free air at 30 °C with insulation

WARNING

To satisfy safety requirements, load wires must be heavy enough not to overheat while carrying the short-circuit output current of the power supply.

Load Consideration

Capacitive Loading

In most cases, the power supply will be stable for almost any size load capacitance. Large load capacitors may cause ringing in the power supply's transient response. It is possible that certain combinations of load capacitance, equivalent series resistance, and load lead inductance will result in instability. If this occurs, the problem may often be solved by either increasing or decreasing the total load capacitance. A large load capacitor may cause the power supply to cross into CC or unregulated mode momentarily when the output voltage is reprogrammed. The slew rate of the output voltage will be limited to the current setting divided by the total load capacitance (internal and external).

Table 7-2 Slew Rate

AWG	Internal Capacitance	Internal Bleed Resistor	Slew Rate at No Load and Full Scale Current Setting
+6V Output	1000 μF	390 Ω	8 V/msec
+25V Output	470 μF	5 k Ω	1.5 V/msec
-25V Output	470 μF	5 k Ω	1.5 V/msec

Inductive loading

Inductive loads present no loop stability problems in constant voltage mode. In constant current mode, inductive loads form a parallel resonance with the power supply's output capacitor. Generally this will not affect the stability of the power supply, but it may cause ringing of the current in the load.

Pulse Loading

In some applications the load current varies periodically from a minimum to a maximum value. The constant current circuit limits the output current. Some peak loading exceeding the current limit can be obtained due to the output capacitor. To stay within the specifications for the output, the current limit should be set greater than the peak current expected or the supply may go into CC mode or unregulated mode for brief periods.

Reverse Current Loading

An active load connected to the supply may actually deliver a reverse current to the supply during a portion of its operating cycle. An external source cannot be allowed to pump current into the supply without risking loss of regulation and possible damage. These effects can be avoided by pre-loading the output with a dummy load resistor. The dummy load resistor should draw at least the same amount of current from the supply as the active load may deliver to the supply. The value of the current for the dummy load plus the value of the current the load draws from the supply must be less than the maximum current of the supply.

Extending the Voltage

The power supply may be able to provide voltages greater than its rated maximum outputs if the power-line voltage is at or above its nominal value. Operation can be extended up to 3% over the rated output without damage to the power supply, but performance cannot be guaranteed to meet specifications in this region. If the power-line voltage is maintained in the upper end of the input voltage range, the power supply will probably operate within its specifications. The power supply is more likely to stay within specifications if only one of the voltage or current outputs is exceeded.

Series Connections

Series operation of two or more power supplies can be accomplished up to the output isolation rating (240 VDC) of any one supply to obtain a higher voltage than that available from a single supply. Series connected power supplies can be operated with one load across both power supplies or with a separate load for each power supply. The power supply has a reverse polarity diode connected across the output terminals so that if operated in series with other power supplies, damage will not occur if the load is short-circuited or if one power supply is turned on separately from its series partners.

When series connection is used, the output voltage is the sum of the voltages of the individual power supplies. The current is the current of any one power supply. Each of the individual power supplies must be adjusted in order to obtain the total output voltage.

In the Keysight E3631A the two 25V supplies can be operated in series to obtain one 0 - 50V supply. The power supply can be put in "Track" mode and then the output will be twice that shown on the front panel. The current will be that of either the +25V supply or the -25V supply.

Remote Programming

During remote programming a constant-voltage regulated power supply is called upon to change its output voltage rapidly. The most important factor limiting the speed of output voltage change is the output capacitor and load resistor.

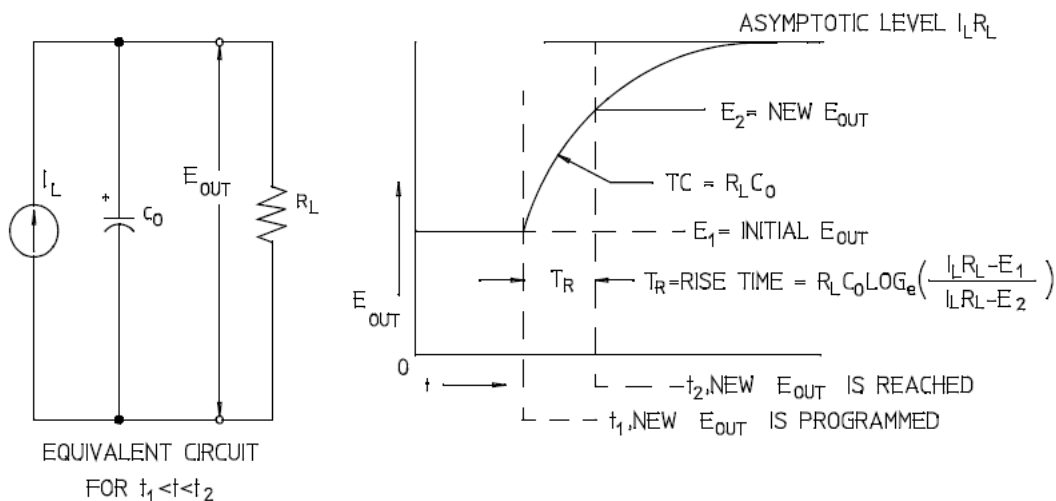

Figure 7-7 Speed of response - programming up (full load)

The equivalent circuit and the nature of the output voltage waveform when the supply is being programmed upward are shown in [Figure 7-7](#). When the new output is programmed, the power supply regulator circuit senses that the output is less than desired and turns on the series regulator to its maximum value I_L , the current limit or constant current setting.

This constant current I_L charges the output capacitor C_0 and load resistor R_L parallel. The output therefore rises exponentially with a time constant $R_L C_0$ towards voltage level $I_L R_L$, a value higher than the new output voltage being programmed.

When this exponential rise reaches the newly programmed voltage level, the constant voltage amplifier resumes its normal regulating action and holds the

output constant. Thus, the rise time can be determined approximately using the formula shown in [Figure 7-7](#).

If no load resistor is attached to the power supply output terminal, then the output voltage will rise linearly at a rate of C_0/I_L when programmed upward, and $T_R = C_0(E_2-E_1)/I_L$, the shortest possible up-programming time.

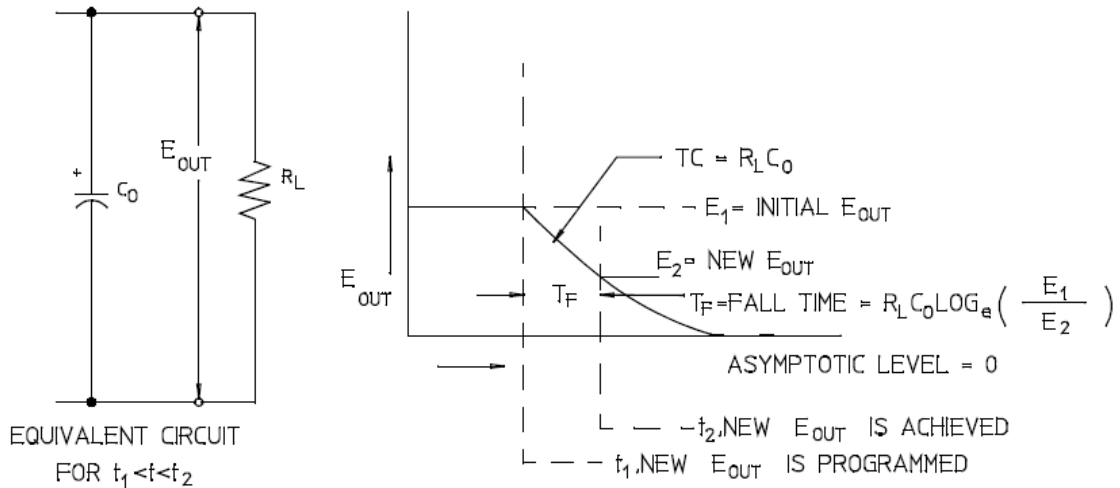

Figure 7-8 Speed of response -programming down

[Figure 7-8](#) shows that when the power supply is programmed down, the regulator senses that the output voltage is higher than desired and turns off the series transistors entirely. Since the control circuit can in no way cause the series regulator transistors to conduct backwards, the output capacitor can only be discharged through the load resistor and internal current source (I_S).

The output voltage decays linearly with slope of I_S/C_0 with no load and stops falling when it reaches the new output voltage which has been demanded. If full load is connected, the output voltage will fall exponentially faster.

Since up-programming speed is aided by the conduction of the series regulating transistor, while down programming normally has no active element aiding in the discharge of the output capacitor, laboratory power supplies normally program upward more rapidly than downward.

Reliability

Reliability of electronic semiconductor equipment depends heavily on the temperature of the components. The lower the temperature of the components, the better the reliability. The Keysight E3631A incorporates circuitry to reduce the internal power dissipation of the power supply and therefore reduce the internal heat of the power supply. Maximum internal power dissipation occurs at maximum current. The internal power dissipation further increases as the output voltage is lowered. A fan internal to the Keysight E3631A is essential to keep internal temperatures low. To assist in cooling the Keysight E3631A the sides and rear of the Keysight E3631A should be kept clear.

THIS PAGE HAS BEEN INTENTIONALLY LEFT BLANK.

8 Specifications

The performance specifications are listed in the following pages. Specifications are warranted in the temperature range of 0 to 40 °C with a resistive load. Supplemental characteristics, which are not warranted but are descriptions of performance determined either by design or testing. The service guide contains procedures for verifying the performance specifications. All specifications apply to three outputs unless otherwise specified.

- Performance Specifications [186](#)
- Supplemental Characteristics [188](#)

Performance Specifications

Output ratings (@ 0 °C - 40 °C)			
+6V Output	0 to +6 V ; 0 to 5 A		
+25V Output	0 to +25 V ; 0 to 1 A		
-25V Output	0 to -25 V ; 0 to 1 A		
Programming accuracy^[1] 12 months (@ 25 °C ± 5 °C), ±(% of output + offset)			
	+6V output	+25V output	-25V output
Voltage	0.1% + 5 mV	0.05% + 20 mV	0.05% + 20 mV
Current	0.2% + 10 mA	0.15% + 4 mA	0.15% + 4 mA
Read back accuracy^[1] 12 months (over GPIB and RS-232 or front panel with respect to actual output @ 25 °C ± 5°C), ±(% of output + offset)			
	+6V output	+25V output	-25V output
Voltage	0.1% + 5 mV	0.05% + 10 mV	0.05% + 10 mV
Current	0.2% + 10 mA	0.15% + 4 mA	0.15% + 4 mA
Ripple and noise (with outputs ungrounded, or with either output terminal grounded, 20 Hz to 20 MHz)			
	+6V output	+25V output	-25V output
Voltage	<0.35 mV rms	<0.35 mV rms	<0.35 mV rms
	<2 mV p-p	<2 mV p-p	<2 mV p-p
Current	<2 mA rms	<500µA rms	<500 µA rms
Common mode current	<1.5 µA rms		
Load regulation, ±(% of output + offset)			
Change in output voltage or current for any load change within ratings.			
Voltage	<0.01% + 2 mV		
Current	<0.01% + 250 µA		

Line regulation, \pm(% of output + offset)			
Change in output voltage and current for any line change within ratings			
Voltage	<0.01% + 2 mV		
Current	<0.01% + 250 μ A		
Programming resolution			
	+6V Output	+25V Output	-25V Output
Voltage	0.5 mV	1.5 mV	1.5 mV
Current	0.5 mA	0.1 mA	0.1 mA
Read back resolution			
	+6V Output	+25V Output	-25V Output
Voltage	0.5 mV	1.5 mV	1.5 mV
Current	0.5 mA	0.1 mA	0.1 mA
Meter resolution			
	+6V Output	+25V Output	-25V Output
Voltage	1 mV	10 mV	10 mV
Current	1 mA	1 mA	1 mA
Transient response time			
Less than 50 μ sec for output recover to within 15 mV following a change in output current from full load to half load or vice versa			
Command processing time			
Programming commands : Maximum time for output to change after receipt of APPLy and SOURce commands) : <50 msec			
Readback command : Maximum time to readback output by MEASure? command : <100 msec			
The other commands : < 50 msec			
Tracking accuracy			
The \pm 25V outputs track each other within \pm (0.2% of output + 20 mV).			

[1] Accuracy specifications are after an 1-hour warm-up and calibration at 25 °C.

Supplemental Characteristics

Output programming range (maximum programmable values)			
	+6V output	+25V output	-25V output
Voltage	0 to 6.18 V	0 to 25.75 V	0 to -25.75 V
Current	0 to 5.15 A	0 to 1.03 A	0 to 1.03 A
Temperature coefficient, ±(% of output + offset) Maximum change in output/readback per °C after a 30-minute warm-up			
	+6V output	+25V output	-25V output
Voltage	0.01% + 2 mV	0.01% + 3 mV	0.01% + 3 mV
Current	0.02% + 3 mA	0.02% + 0.5 mA	0.02% + 0.5 mA
Stability, ±(% of output + offset) Following a 30-minute warm-up, with the output in the ON state according to the operating mode (CC with load or CV), and with a change in the output over 8 hours under constant load, line, and ambient temperature			
	+6V output	+25V output	-25V output
Voltage	0.03% + 1 mV	0.02% + 2 mV	0.02% + 2 mV
Current	0.1% + 3 mA	0.05% + 1 mA	0.05% + 1 mA
Voltage programming speed Maximum time required for output voltage to settle within 1% of its total excursion (for resistive load). Excludes command processing time.			
	+6V output	+25V output	-25V output
Full load Up	11 msec	50 msec	50 msec
Full load Down	13 msec	45 msec	45 msec
No load Up	10 msec	20 msec	20 msec
No load Down	200 msec	400 msec	400 msec
Isolation			
The 0-6V supply is isolated from the ±25V supply up to ±240 Vdc. Maximum isolation voltage from any terminal to chassis ground ±240 Vdc.			
AC input ratings (selectable via rear panel selector)			
std	115 Vac ± 10%, 47 to 63 Hz, 350 VA Max		

opt 0E3	230 VAC \pm 10%, 47 to 63 Hz, 350 VA Max
---------	--

opt 0E9	100 VAC \pm 10%, 47 to 63 Hz, 350 VA Max
---------	--

Cooling

Fan cooled

Operating temperature

0 to 40 °C for full rated output. At higher temperatures, the output current is derated linearly to 50% at 55 °C maximum temperature.

Output voltage overshoot

During turn-on or turn-off of ac power, output plus overshoot will not exceed 1 V if the output control is set to less than 1 V. If the output control is set to 1 V or higher, there is no overshoot.

Programming language

SCPI (Standard Commands for Programmable Instruments)

State storage memory

Three (3) user-configurable stored states

Recommended calibration interval

1 year

Dimensions*

212.6 mmW x 132.6 mmH x 348.2 mmD (8.4 x 5.2 x 13.7 in)

*See the next page for detailed information.

Weight

Net	8.2 kg (18 lb)
-----	----------------

Shipping	11 kg (24 lb)
----------	---------------

Specifications

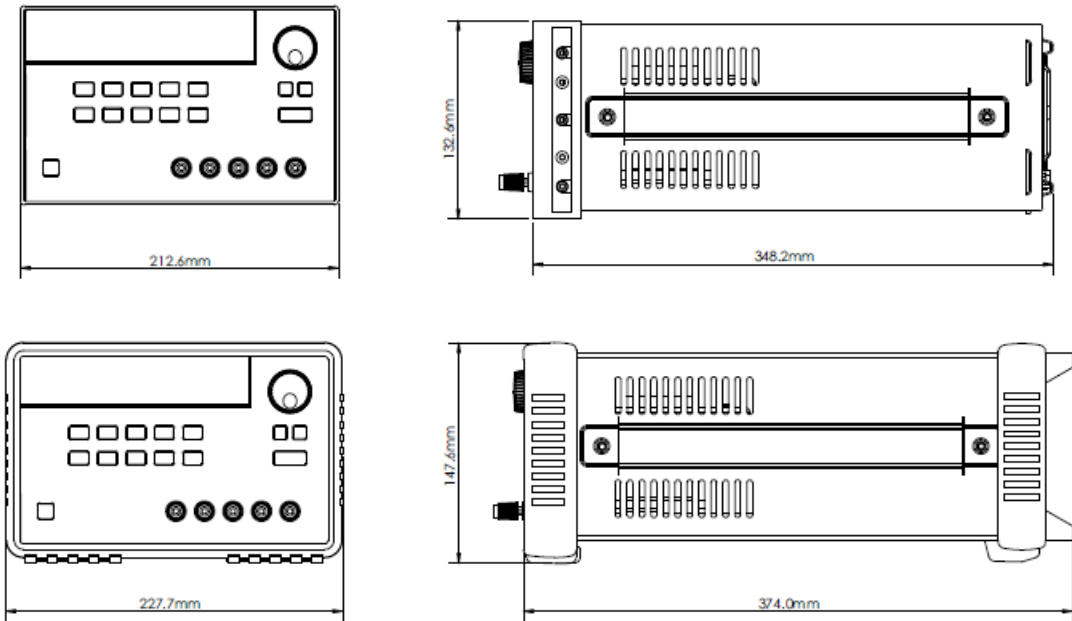

Figure 8-1 Dimensions of keysight E3631A power supply



This information is subject to change without notice. Always refer to the Keysight website for the latest revision.

© Keysight Technologies 2002 - 2018
Edition 10, December 1, 2018

Printed in Malaysia



E3631-90002

www.keysight.com